

# EMC TEST REPORT



## For Electromagnetic Interference of

Report Reference No. ....: EA1705036E 01001

Engineer (name + signature) .....: Taric Yang 

Approved by (name + signature).....: Fred Zhu 

Date of issue .....: Jul. 24, 2017

Testing Laboratory.....: Dongguan Anci Electronic Technology Co., Ltd.

Address .....: 1-2 Floor, Building A, No.11, Headquarters 2 Road, Songshan Lake  
Hi-tech Industrial Development Zone, Dongguan City, Guangdong,  
China

Applicant's name .....:

Address .....:

Manufacturer .....:

Address .....:

Test specification:

Test item description .....: Pen holder USB charger

Trade Mark .....: N/A

Model/Type reference .....: P308.91

Ratings .....: Input rating: 100-240V~, 50/60Hz, 0.6Amax  
Output rating: 5.0Vdc, each port 2.4A Max.(Total 4.1A Max)

<b>Table of Contents</b>	<b>Page</b>
<b>1 .GENERAL INFORMATION</b>	<b>5</b>
1.1 CERTIFICATION	5
1.2. PRODUCT INFORMATION	6
<b>2. SUMMARY OF TEST RESULTS</b>	<b>7</b>
2.1 MEASUREMENT UNCERTAINTY	8
2.2 DESCRIPTION OF TEST MODES	8
2.3 BLOCK DIGRAM SHOWING THE CONFIGURATION OF SYSTEM TESTED	9
<b>3. EMISSION TEST</b>	<b>10</b>
3.1 CONDUCTED EMISSION MEASUREMENT	10
3.1.1 LIMITS OF CONDUCTED EMISSION(MAINS PORT)	10
3.1.2 MEASUREMENT INSTRUMENTS LIST	10
3.1.3 TEST PROCEDURE	10
3.1.4 DEVIATION FROM TEST STANDARD	10
3.1.5 TEST SETUP	11
3.1.6 EUT OPERATING CONDITIONS	11
3.1.7 TEST RESULTS	12
3.2 RADIATED EMISSION MEASUREMENT	15
3.2.1 LIMITS OF RADIATED EMISSION MEASUREMENT	15
3.2.2 MEASUREMENT INSTRUMENTS LIST	15
3.2.3 TEST PROCEDURE	16
3.2.4 DEVIATION FROM TEST STANDARD	16
3.2.5 TEST SETUP	17
3.2.6 EUT OPERATING CONDITIONS	17
3.2.7 TEST RESULTS	18
3.3 HARMONICS CURRENT MEASUREMENT	21
3.3.1 LIMITS OF HARMONICS CURRENT MEASUREMENT	21
3.3.2 MEASUREMENT INSTRUMENTS LIST	22
3.3.3 TEST PROCEDURE	22
3.3.4 DEVIATION FROM TEST STANDARD	22
3.3.5 TEST SETUP	22
3.3.6 EUT OPERATING CONDITIONS	22
3.3.7 TEST RESULTS	22
3.4 VOLTAGE FLUCTUATION AND FLICKS MEASUREMENT	23
3.4.1 LIMITS OF VOLTAGE FLUCTUATION AND FLICKSMEASUREMENT	23
3.4.2 MEASUREMENT INSTRUMENTS LIST	23
3.4.3 TEST PROCEDURE	23

<b>Table of Contents</b>	<b>Page</b>
3.4.4 DEVIATION FROM TEST STANDARD	23
3.4.5 TEST SETUP	24
<b>4.IMMUNITY TEST</b>	<b>25</b>
4.1 STANDARD COMPLIANCE/SERVURITY LEVEL/CRITERIA	25
4.2 GENERAL PERFORMANCE CRITERIA	26
4.3 GENERAL PERFORMANCE CRITERIA TEST SETUP	26
4.4 ESD TESTING	27
4.4.1 TEST SPECIFICATION	27
4.4.2 MEASUREMENT INSTRUMENTS	27
4.4.3 TEST PROCEDURE	27
4.4.4 DEVIATION FROM TEST STANDARD	28
4.4.5 TEST SETUP	28
4.4.6 TEST RESULTS	29
4.5 RS TESTING2	30
4.5.1 TEST SPECIFICATION	30
4.5.2 MEASUREMENT INSTRUMENTS	30
4.5.3 TEST PROCEDURE	30
4.5.4 DEVIATION FROM TEST STANDARD	30
4.5.5 TEST SETUP	31
4.5.6 TEST RESULTS	32
4.6 EFT/BURST TESTING	33
4.6.1 TEST SPECIFICATION	33
4.6.2 MEASUREMENT INSTRUMENTS	33
4.6.3 TEST PROCEDURE	33
4.6.4 DEVIATION FROM TEST STANDARD	33
4.6.5 TEST SETUP	34
4.6.6 TEST RESULTS	35
4.7 SURGE TESTING	36
4.7.1 TEST SPECIFICATION	36
4.7.2 MEASUREMENT INSTRUMENTS	36
4.7.3 TEST PROCEDURE	36
4.7.4 DEVIATION FROM TEST STANDARD	37
4.7.5 TEST SETUP	37
4.7.6 TEST RESULTS	38
4.8 INJECTION CURRENT TESTING	39
4.8.1 TEST SPECIFICATION	39
4.8.2 MEASUREMENT INSTRUMENTS	39
4.8.3 TEST PROCEDURE	39

<b>Table of Contents</b>	<b>Page</b>
4.8.4 DEVIATION FROM TEST STANDARD	39
4.8.5 TEST SETUP	40
4.8.6 TEST RESULTS	41
4.9 VOLTAGE INTERRUPTION/DIPS TESTING	42
4.9.1 TEST SPECIFICATION	42
4.9.2 MEASUREMENT INSTRUMENTS	42
4.9.3 TEST PROCEDURE	42
4.9.4 DEVIATION FROM TEST STANDARD	42
4.9.5 TEST SETUP	43
4.9.6 TEST RESULTS	43
4.10 POWER-FREQUENCY MAGNETIC FILDS	44
4.10.1 MEASUREMENT INSTRUMENTS	44
4.10.2 TEST LEVEL AND PERFORMANCE CRITERION	44
4.10.3 TEST PROCEDURE	44
4.10.4 DEVIATION FROM TEST STANDARD	44
4.10.5 TEST SETUP	45
4.10.6 TEST RESULTS	45
5. ATTACHMENT	46
5.1 EUT TEST PHOTO	46
5.2 EUT PHOTO	48



**1 .GENERAL INFORMATION**

**1.1 CERTIFICATION**

Testing Laboratory.....: Dongguan Anci Electronic Technology Co., Ltd.  
 Address .....: 1-2 Floor, Building A, No.11, Headquarters 2 Road, Songshan  
 Lake Hi-tech Industrial Development Zone, Dongguan City,  
 Guangdong, China

Applicant's name.....:  
 Address .....

Manufacturer .....

First Factory's name.....:  
 Address.....

**Test specification:**

Test item description .....: Pen holder USB charger  
 Trade Mark .....: N/A  
 Model/Type reference .....: P308.91  
 Test Sample.....: P308.91  
 Ratings .....: Input rating: 100-240V~, 50/60Hz, 0.6Amax  
 Output rating: 5.0Vdc, each port 2.4A Max.(Total 4.1A Max)  
 Tested Power.....: I/P: 230Vac, 50Hz  
 Standards .....: EN 55032: 2015  
 EN 55024: 2010+A1:2015  
 EN 61000-3-2:2014  
 EN 61000-3-3:2013

The device described above was tested by Dong Guan Anci Electronic Technology Co., Ltd. to determine the maximum emission levels emanated from the device and severity levels of the device endure and its performance criterion. The measurement results are contained in this test report and Dong Guan Anci Electronic Technology Co., Ltd. assumes full responsibility for the accuracy and completeness of these measurements. This report shows the EUT is technically compliance with the above official standards.

This report applies to the above sample only and shall not be reproduced in part without written approval of Dong Guan Anci Electronic Technology Co., Ltd.

## 1.2. PRODUCT INFORMATION

The equipment model P308.91 is Pen holder USB charger for the use in information technology equipment.

## 2. SUMMARY OF TEST RESULTS

Test procedures according to the technical standards:

<b>Emission</b>				
Standard	Test Item	Limit	Judgment	Remark
EN 55032: 2015	Conducted Emission	Class B	PASS	
	Radiated Emission	Class B	PASS	
EN 61000-3-2:2014	Harmonic Current Emission	Class D	PASS	
EN 61000-3-3:2013	Voltage Fluctuations & Flicker	Clause 5	PASS	
<b>Immunity (EN 55024: 2010+A1:2015)</b>				
Section	Test Item	Performance Criteria	Judgment	Remark
EN 61000-4-2:2009	Electrostatic Discharge	B	PASS	
EN 61000-4-3:2006 +A1:2008+A2: 2010	RF electromagnetic field	A	PASS	
EN 61000-4-4:2012	Fast transients	B	PASS	
EN 61000-4-5:2014	Surges	B	PASS	
EN 61000-4-6:2014	Injected Current	A	PASS	
EN 61000-4-8:2010	Power Frequency Magnetic Field	A	PASS	
EN 61000-4-11:2004	Volt. Interruptions Volt. Dips	B / C / C <b>NOTE (3)</b>	PASS	

**NOTE:**

- (1) "N/A" denotes test is not applicable in this Test Report
- (2) The power consumption of EUT is less than 75W and no Limits apply.
- (3) Voltage dip: >95% reduction – Performance Criteria **B**  
 Voltage dip: 30% reduction – Performance Criteria **C**  
 Voltage Interruption: >95% reduction – Performance Criteria **C**

**2.1 MEASUREMENT UNCERTAINTY**

The reported uncertainty of measurement  $y \pm U$ , where expanded uncertainty  $U$  is based on a standard uncertainty multiplied by a coverage factor of  $k=2$ , providing a level of confidence of approximately 95 %.

A. Conducted Measurement :

Test Site	Method	Measurement Frequency Range	U (dB)	NOTE
C01	ANSI	150 KHz ~ 30MHz	2.54	

B. Radiated Measurement :

Test Site	Method	Measurement Frequency Range	Ant. H / V	U(dB)	NOTE
OS02	ANSI	30MHz ~ 200MHz	V	3.0	
		30MHz ~ 200MHz	H	3.0	
		200MHz ~ 1,000MHz	V	3.0	
		200MHz ~ 1,000MHz	H	3.0	

**2.2 DESCRIPTION OF TEST MODES**

To investigate the maximum EMI emission characteristics generates from EUT, the test system was pre-scanning tested base on the consideration of following EUT operation mode or test configuration mode which possible have effect on EMI emission level. Each of these EUT operation mode(s) or test configuration mode(s) mentioned above was evaluated respectively.

For Conducted Test	
Test Mode	Description
Mode 1	Full Load

For Radiated Test	
Test Mode	Description
Mode 1	Full Load

For EMS Test	
Test Mode	Description
Mode 1	Full Load



### 2.3 BLOCK DIGRAM SHOWING THE CONFIGURATION OF SYSTEM TESTED

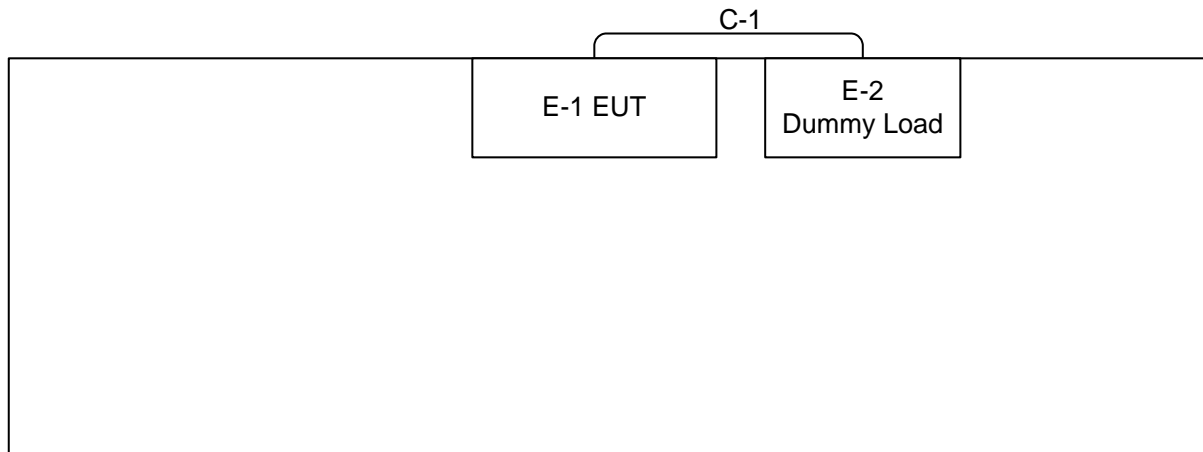

C-1 Power Cable

**3. EMISSION TEST**

**3.1 CONDUCTED EMISSION MEASUREMENT**

**3.1.1 LIMITS OF CONDUCTED EMISSION(MAINS PORT) (Frequency Range 150KHz-30MHz)**

FREQUENCY (MHz)	Class A (dBuV)		Class B (dBuV)	
	Quasi-peak	Average	Quasi-peak	Average
0.15 -0.5	79.00	66.00	66 - 56 *	56 - 46 *
0.50 -5.0	73.00	60.00	56.00	46.00
5.0 -30.0	73.00	60.00	60.00	50.00

Note:

- (1) The tighter limit applies at the band edges.
- (2) The limit of " \* " marked band means the limitation decreases linearly with the logarithm of the frequency in the range.

**3.1.2 MEASUREMENT INSTRUMENTS LIST**

Item	Kind of Equipment	Manufacturer	Type No.	Serial No.	Calibrated until
1	LISN	SCHWARZBECK MESS-ELEKTRONIK	NSLK 8127	8127-669	2018-06-11
2	Pulse Limiter	ROHDE&SCHWARZ	ESH3-Z2	101661	2018-06-11
3	Test Cable	N/A	C01	N/A	2018-06-11
4	EMI Test Receiver	ROHDE&SCHWARZ	ESCI	101358	2018-06-11

Remark: " N/A" denotes No Model No. , Serial No. or No Calibration specified.

**3.1.3 TEST PROCEDURE**

- a. The EUT was placed 0.4 meters from the horizontal ground plane with EUT being connected to the power mains through a line impedance stabilization network (LISN). All other support equipments powered from additional LISN(s). The LISN provide 50 Ohm/ 50uH of coupling impedance for the measuring instrument.
- b. Interconnecting cables that hang closer than 40 cm to the ground plane shall be folded back and forth in the center forming a bundle 30 to 40 cm long.
- c. I/O cables that are not connected to a peripheral shall be bundled in the center. The end of the cable may be terminated, if required, using the correct terminating impedance. The overall length shall not exceed 1 m.
- d. LISN at least 80 cm from nearest part of EUT chassis.
- e. For the actual test configuration, please refer to the related Item –EUT Test Photos.

**3.1.4 DEVIATION FROM TEST STANDARD**

No deviation

### 3.1.5 TEST SETUP

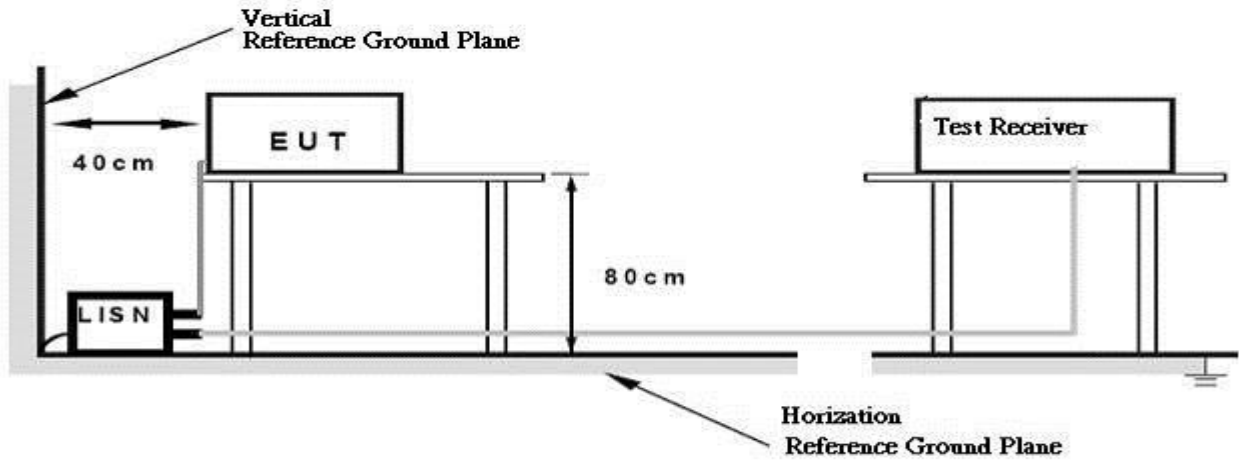

### 3.1.6 EUT OPERATING CONDITIONS

The EUT exercise program used during radiated and/or conducted emission measurement was designed to exercise the various system components in a manner similar to a typical use.

**3.1.7 TEST RESULTS**

<b>EUT:</b>	Pen holder USB charger	<b>Model No.:</b>	P308.91
<b>Temperature:</b>	22°C	<b>Relative Humidity:</b>	52 %
<b>Pressure:</b>	1008 hPa	<b>Test Power :</b>	AC 230V/50Hz
<b>Test Mode :</b>	Full Load		

**Remark:**

- (1) Reading in which marked as QP means measurements by using Quasi-Peak Detector ,and AV means measurements by using Average Detector.
- (2) All readings are QP Mode value unless otherwise stated AVG in column of 『Note』 . If the QP Mode Measured value compliance with the QP Limits and lower than AVG Limits, the EUT shall be deemed to meet both QP & AVG Limits and then only QP Mode was measured, but AVG Mode didn't perform. In this case, a “ \* ” marked in AVG Mode column of Interference Voltage Measured.
- (3) Measuring frequency range from 150KHz to 30MHz.

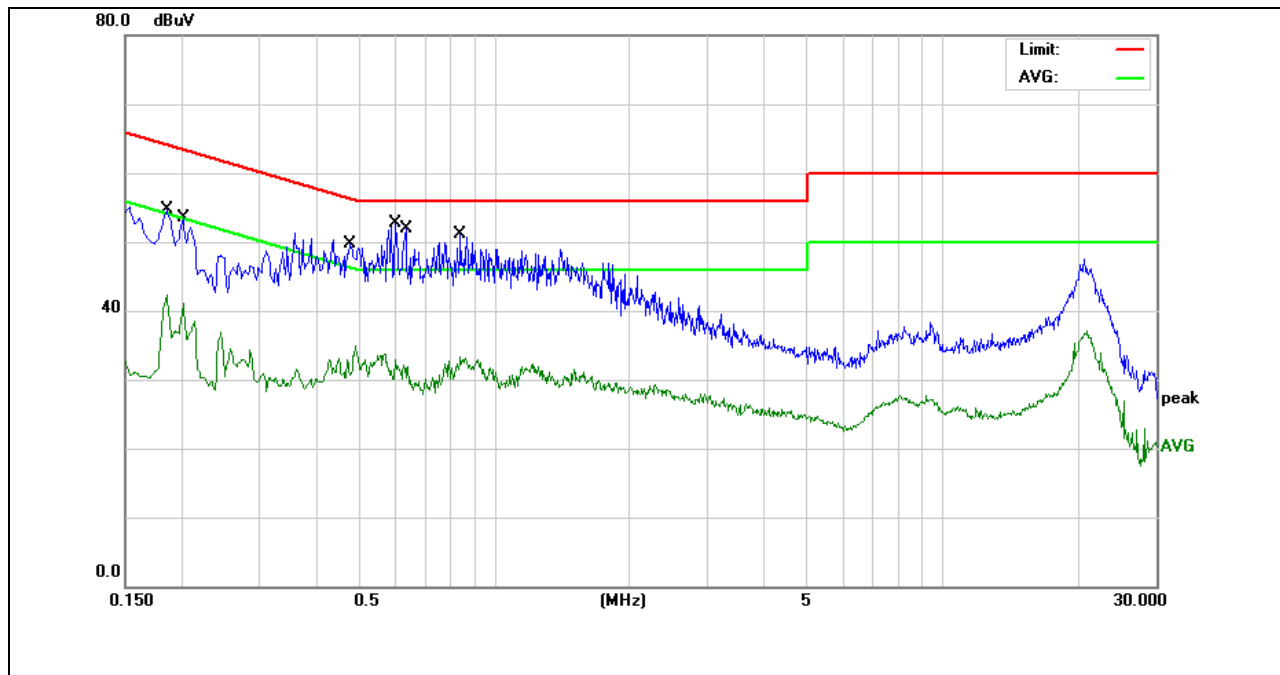

<b>Site:</b> 843	<b>Phase:</b> N	<b>Temperature(C):</b> 22(C)
<b>Limit:</b> EN55032 Class B Conduction(QP)		<b>Humidity(%):</b> 52%
<b>EUT:</b> Pen holder USB charger	<b>Test Time:</b> 2017-07-22	
<b>M/N.:</b> P308.91	<b>Power Rating:</b> AC 230V/50Hz	
<b>Mode:</b> Full Load	<b>Test Engineer:</b>	
<b>Note:</b>		

No.	Frequency (MHz)	Reading Level(dBuV)	Factor (dB)	Measurement(dBuV)	Limit (dBuV)	Over (dB)	Detector	Comment
1	0.1860	40.43	9.58	50.01	64.21	-14.20	QP	
2	0.1860	28.08	9.58	37.66	54.21	-16.55	AVG	
3	0.2020	39.55	9.60	49.15	63.52	-14.37	QP	
4	0.2020	27.52	9.60	37.12	53.52	-16.40	AVG	
5	0.4780	31.27	9.73	41.00	56.37	-15.37	QP	
6	0.4780	21.18	9.73	30.91	46.37	-15.46	AVG	
7	0.6020	31.46	9.72	41.18	56.00	-14.82	QP	
8	0.6020	21.43	9.72	31.15	46.00	-14.85	AVG	
9	0.6340	31.05	9.71	40.76	56.00	-15.24	QP	
10	0.6340	21.41	9.71	31.12	46.00	-14.88	AVG	
11	0.8420	30.84	9.70	40.54	56.00	-15.46	QP	
12 *	0.8420	22.80	9.70	32.50	46.00	-13.50	AVG	

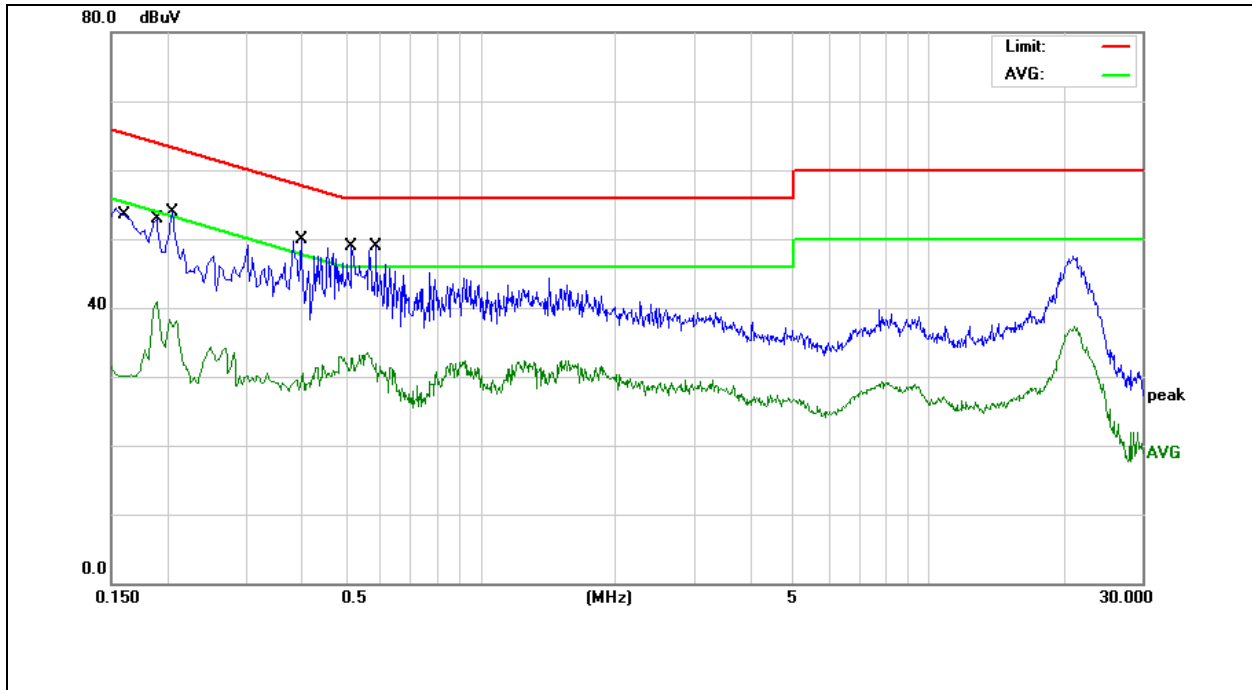

<b>Site:</b> 843	<b>Phase:</b> L1	<b>Temperature(C):</b> 22(C)
<b>Limit:</b> EN55032 Class B Conduction(QP)		<b>Humidity(%):</b> 52%
<b>EUT:</b> Pen holder USB charger	<b>Test Time:</b> 2017-07-22	
<b>M/N.:</b> P308.91	<b>Power Rating:</b> AC 230V/50Hz	
<b>Mode:</b> Full Load	<b>Test Engineer:</b>	
<b>Note:</b>		

No.	Frequency (MHz)	Reading Level(dBuV)	Factor (dB)	Measurement(dBuV)	Limit (dBuV)	Over (dB)	Detector	Comment
1	0.1624	27.93	9.54	37.47	65.34	-27.87	QP	
2	0.1624	18.74	9.54	28.28	55.34	-27.06	AVG	
3	0.1884	38.37	9.59	47.96	64.10	-16.14	QP	
4	0.1884	27.64	9.59	37.23	54.10	-16.87	AVG	
5	0.2060	36.19	9.60	45.79	63.36	-17.57	QP	
6	0.2060	25.86	9.60	35.46	53.36	-17.90	AVG	
7	0.3980	30.92	9.69	40.61	57.89	-17.28	QP	
8	0.3980	19.27	9.69	28.96	47.89	-18.93	AVG	
9	0.5180	30.48	9.74	40.22	56.00	-15.78	QP	
10 *	0.5180	21.53	9.74	31.27	46.00	-14.73	AVG	
11	0.5860	30.43	9.72	40.15	56.00	-15.85	QP	
12	0.5860	21.23	9.72	30.95	46.00	-15.05	AVG	

### 3.2 RADIATED EMISSION MEASUREMENT

#### 3.2.1 LIMITS OF RADIATED EMISSION MEASUREMENT (Below 1000MHz)

FREQUENCY (MHz)	Class A (at 3m)		Class B (at 3m)	
	dBuV/m		dBuV/m	
30 – 230	50		40	
230 – 1000	57		47	

Notes:

- (1) The limit for radiated test was performed according to as following:  
EN 55032/CISPR 32.
- (2) The tighter limit applies at the band edges.
- (3) Emission level (dBuV/m)=20log Emission level (uV/m).

#### LIMITS OF RADIATED EMISSION MEASUREMENT (Above 1000MHz)

FREQUENCY (GHz)	Class A (dBuV/m) (at 3m)		Class B (dBuV/m) (at 3m)	
	PEAK	AVERAGE	PEAK	AVERAGE
1 ~ 3	76	56	74	54
3 ~ 6	80	60	70	50

Notes:

- (1) The limit for radiated test was performed according to EN 55032/CISPR 32.
- (2) The tighter limit applies at the band edges.
- (3) Emission level (dBuV/m)=20log Emission level (uV/m).

#### 3.2.2 MEASUREMENT INSTRUMENTS LIST

Item	Kind of Equipment	Manufacturer	Type No.	Serial No.	Calibrated until
1	Log-Bicon Antenna	SCHWARZBECK MESS	VULB 9163	9168-588	2018-06-15
2	Test Cable	N/A	10M_OS01	N/A	2018-06-11
3	Test Cable	N/A	C01-1/-2	N/A	2018-06-11
4	Pre-Amplifier	HP	8447D	N/A	2018-06-11
6	Test Receiver	ROHDE&SCHWARZ	ESPI	100582	2018-01-12
7	Antenna Mast	N/A	N/A	N/A	N/A
8	Turn Table	N/A	N/A	N/A	N/A
9	Positioning Controller	Max-Full Antenna Corp.	MF7802	N/A	N/A

Remark: " N/A" denotes No Model No. / Serial No. and No Calibration specified.

### 3.2.3 TEST PROCEDURE

- a. The measuring distance of at 3m or 10 m shall be used for measurements at frequency up to 1GHz. For frequencies above 1GHz, any suitable measuring distance may be used.
- b. The EUT was placed on the top of a rotating table 0.8 meters above the ground at a 3m or 10 meter open area test site. The table was rotated 360 degrees to determine the position of the highest radiation.
- c. The height of the equipment or of the substitution antenna shall be 0.8 m; the height of the test antenna shall vary between 1 m to 4 m. Both horizontal and vertical polarizations of the antenna are set to make the measurement.
- d. The initial step in collecting conducted emission data is a spectrum analyzer peak detector mode pre-scanning the measurement frequency range. Significant peaks are then marked and then Quasi Peak detector mode re-measured.
- e. If the Peak Mode measured value compliance with and lower than Quasi Peak Mode Limit, the EUT shall be deemed to meet QP Limits and then no additional QP Mode measurement performed.
- f. For the actual test configuration, please refer to the related Item –EUT Test Photos.

### 3.2.4 DEVIATION FROM TEST STANDARD

No deviation



### 3.2.5 TEST SETUP

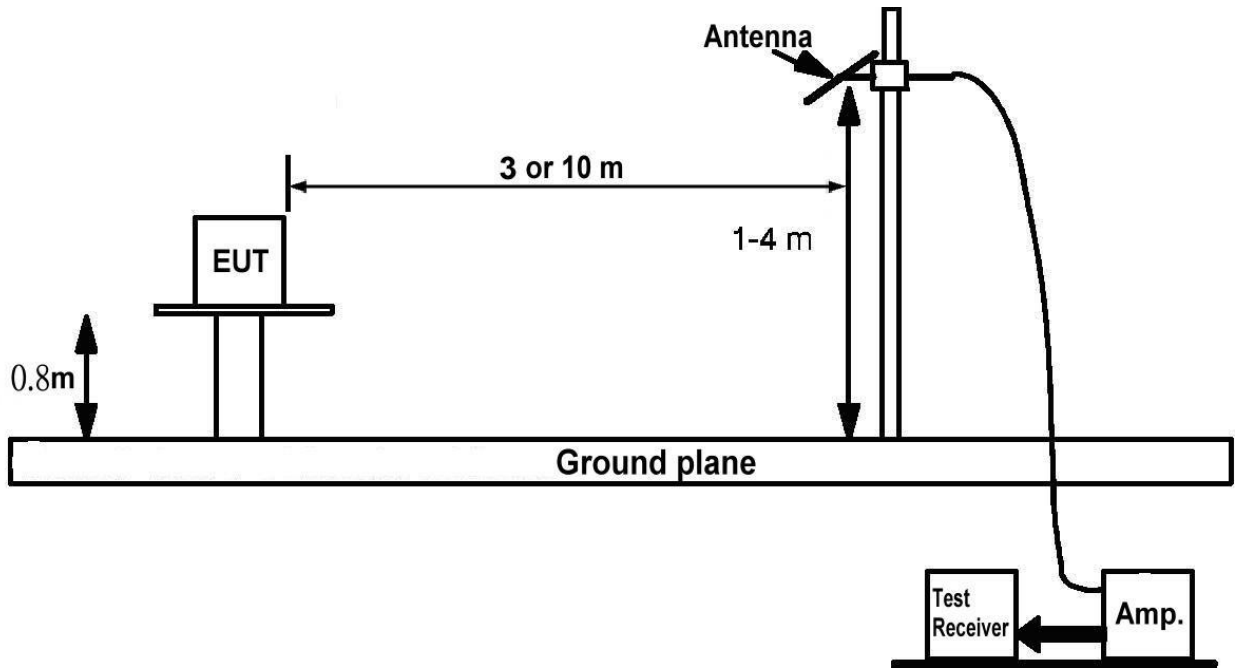

### 3.2.6 EUT OPERATING CONDITIONS

The EUT tested system was configured as the statements of 3.1.6 Unless otherwise a special operating condition is specified in the follows during the testing.

**3.2.7 TEST RESULTS**

<b>EUT:</b>	Pen holder USB charger	<b>Model No.:</b>	P308.91
<b>Temperature:</b>	22°C	<b>Relative Humidity:</b>	52 %
<b>Pressure:</b>	1008 hPa	<b>Test Power :</b>	AC 230V/50Hz
<b>Test Mode :</b>	Full Load		

Remark :

- (1) Reading in which marked as QP or Peak means measurements by using are Quasi-Peak Detector or Peak Detector.
- (2) All readings are Peak unless otherwise stated QP in column of 『Note』 . Peak denotes that the Peak reading compliance with the QP Limits and then QP Mode measurement didn't perform.
- (3) Measuring frequency range from 30MHz to 1000MHz.
- (4) If the peak scan value lower limit more than 20dB, then this signal data does not show in table.

## Radiated Emission Test Result

<b>Test Site</b>	: 966 Chamber	<b>Tested By</b>	: Sam
<b>Test Date</b>	: 2017-07-22	<b>Model Number</b>	: P308.91
<b>EUT</b>	: Pen holder USB charger	<b>Test Mode</b>	: Full Load
<b>Power Supply</b>	: AC 230V/50Hz	<b>Antenna/Distance</b>	: VULB9163-1/3m
<b>Condition</b>	: Temp:21°C ,Humi:51%		
<b>Memo</b>	:		

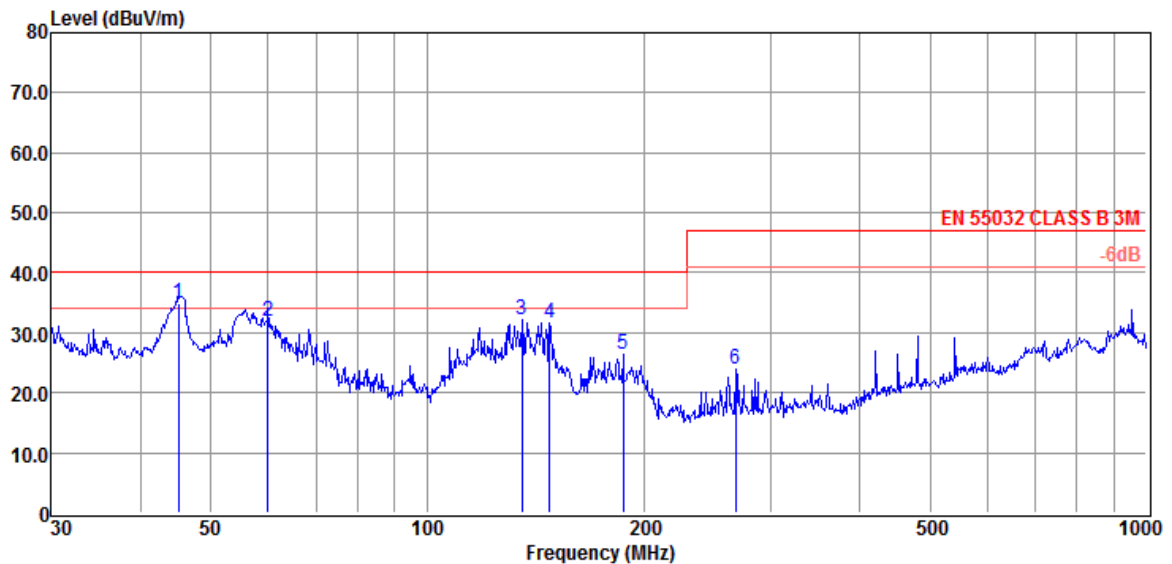

Item (Mark)	Freq (MHz)	Read Level (dBμV)	Factor dB	Level (dBμV/m)	Limit Line (dBμV/m)	Over Limit (dB)	Detector	Polarization
1	45.06	45.10	-10.11	34.99	40.00	-5.01	QP	VERTICAL
2	60.07	43.10	-11.07	32.03	40.00	-7.97	QP	VERTICAL
3	135.51	46.22	-14.18	32.04	40.00	-7.96	Peak	VERTICAL
4	147.92	45.85	-14.24	31.61	40.00	-8.39	Peak	VERTICAL
5	187.10	38.31	-11.85	26.46	40.00	-13.54	Peak	VERTICAL
6	268.49	32.43	-8.64	23.79	47.00	-23.21	Peak	VERTICAL

Note: 1. Result Level = Read Level + Factor  
 2. If PK Result complies with QP limit, QP Result is deemed to comply with QP limit

## Radiated Emission Test Result

<b>Test Site</b>	: 966 Chamber	<b>Tested By</b>	: Sam
<b>Test Date</b>	: 2017-07-22	<b>Model Number</b>	: P308.91
<b>EUT</b>	: Pen holder USB charger	<b>Test Mode</b>	: Full Load
<b>Power Supply</b>	: AC 230V/50Hz	<b>Antenna/Distance</b>	: VULB9163-1/3m
<b>Condition</b>	: Temp:21°C,Humi:51%		
<b>Memo</b>	:		

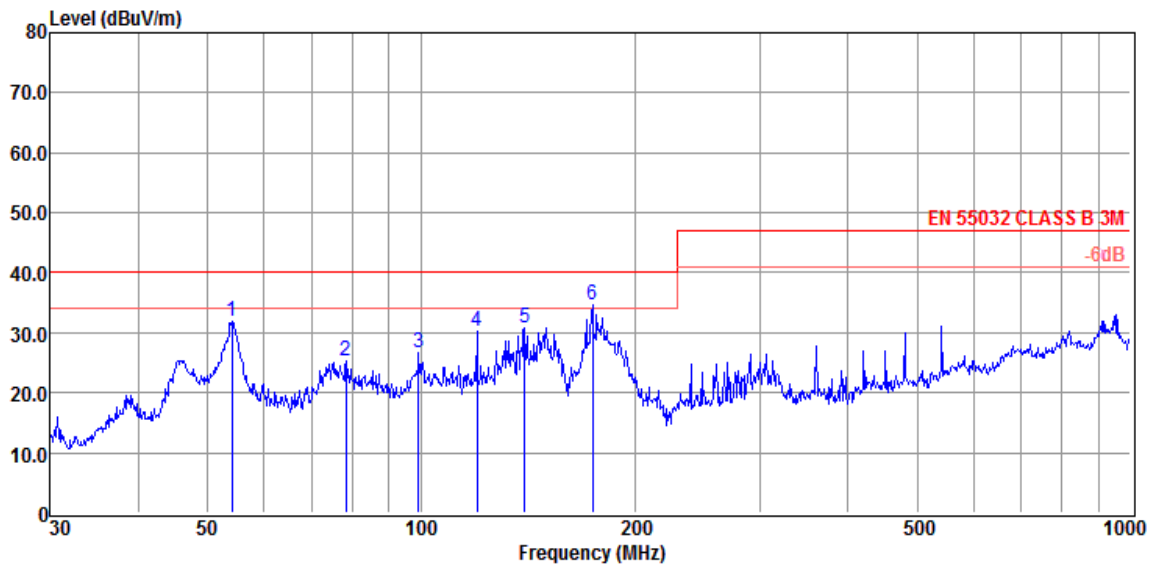

Item (Mark)	Freq (MHz)	Read Level (dBμV)	Factor dB	Level (dBμV/m)	Limit Line (dBμV/m)	Over Limit (dB)	Detector	Polarization
1	54.07	41.76	-9.95	31.81	40.00	-8.19	Peak	HORIZONTAL
2	78.41	40.25	-14.90	25.35	40.00	-14.65	Peak	HORIZONTAL
3	99.18	37.39	-10.66	26.73	40.00	-13.27	Peak	HORIZONTAL
4	119.86	42.64	-12.31	30.33	40.00	-9.67	Peak	HORIZONTAL
5	139.85	45.25	-14.32	30.93	40.00	-9.07	Peak	HORIZONTAL
6	174.42	47.62	-12.98	34.64	40.00	-5.36	Peak	HORIZONTAL

Note: 1. Result Level = Read Level + Factor  
 2. If PK Result complies with QP limit, QP Result is deemed to comply with QP limit

### 3.3 HARMONICS CURRENT MEASUREMENT

#### 3.3.1 LIMITS OF HARMONICS CURRENT MEASUREMENT

**Table 1 – Limits for Class A equipment**

Harmonic order n	Maximum permissible harmonic current A
<b>Odd harmonics</b>	
3	2,30
5	1,14
7	0,77
9	0,40
11	0,33
13	0,21
$15 \leq n \leq 39$	$0,15 \frac{15}{n}$
<b>Even harmonics</b>	
2	1,08
4	0,43
6	0,30
$8 \leq n \leq 40$	$0,23 \frac{8}{n}$

**Table 2 – Limits for Class C equipment**

Harmonic order n	Maximum permissible harmonic current expressed as a percentage of the input current at the fundamental frequency %
2	2
3	$30 \cdot \lambda^*$
5	10
7	7
9	5
$11 \leq n \leq 39$ (odd harmonics only)	3

\*  $\lambda$  is the circuit power factor

**Table 3 – Limits for Class D equipment**

Harmonic order n	Maximum permissible harmonic current per watt mA/W	Maximum permissible harmonic current A
3	3,4	2,30
5	1,9	1,14
7	1,0	0,77
9	0,5	0,40
11	0,35	0,33
$13 \leq n \leq 39$ (odd harmonics only)	$\frac{3,85}{n}$	See Table 1

**3.3.2 MEASUREMENT INSTRUMENTS LIST**

Item	Kind of Equipment	Manufacturer	Type No.	Serial No.	Calibrated until
1	Harmonic & Flicker	California	PACS-1	72344	2018-06-05
2	Power Source	California	3001iX	56309	2018-06-05

Remark: " N/A" denotes No Model No. / Serial No. and No Calibration specified.

**3.3.3 TEST PROCEDURE**

- a. Test was performed according to the procedures specified in Clause 5.0 of IEC555-2 and/or Sub-clause 6.2 of IEC/EN 61000-3-2 depend on which standard adopted for compliance measurement.
- b. All types of harmonic current and/or voltage fluctuation in this report are assessed by direct measurement using flicker-meter.
- c. For the actual test configuration, please refer to the related Item –EUT Test Photos.

**3.3.4 DEVIATION FROM TEST STANDARD**

No deviation

**3.3.5 TEST SETUP**

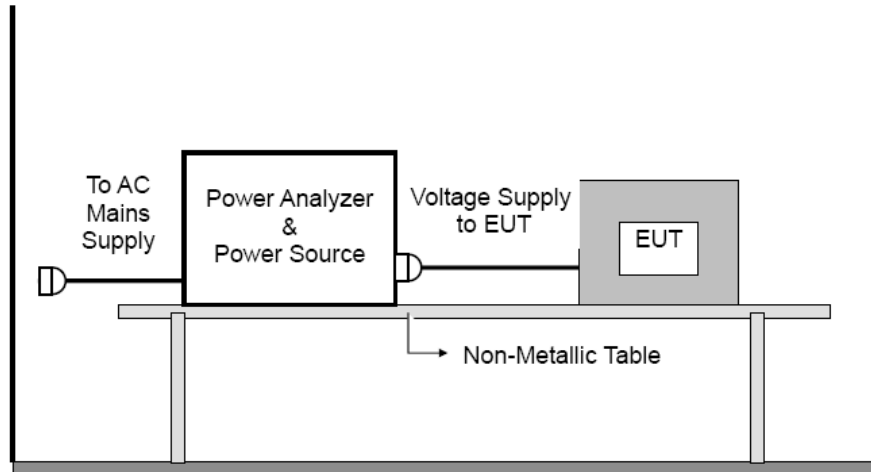

**3.3.6 EUT OPERATING CONDITIONS**

The EUT tested system was configured as the statements of 3.1.6 Unless otherwise a special operating condition is specified in the follows during the testing.

**3.3.7 TEST RESULTS**

The power consumption is less than 75W, so no limit is applicable.

### 3.4 VOLTAGE FLUCTUATION AND FLICKS MEASUREMENT

#### 3.4.1 LIMITS OF VOLTAGE FLUCTUATION AND FLICKSMEASUREMENT

Tests	Limits		Descriptions
	IEC555-3	IEC/EN 61000-3-2	
Pst	≤ 1.0, Tp= 10 min.	≤ 1.0, Tp= 10 min.	Short Term Flicker Indicator
Plt	N/A	≤ 0.65, Tp=2 hr.	Long Term Flicker Indicator
dc	≤ 3 %	≤ 3.3 %	Relative Steady-State V-Chang
dmax	≤ 4 %	≤ 4 %	Maximum Relative V-change
d (t)	N/A	≤ 3.3% for > 500 ms	Relative V-change characteristic

#### 3.4.2 MEASUREMENT INSTRUMENTS LIST

Item	Kind of Equipment	Manufacturer	Type No.	Serial No.	Calibrated until
1	Harmonic & Flicker	California	PACS-1	72344	2018-06-05
2	Power Source	California	3001iX	56309	2018-06-05

Remark: " N/A" denotes No Model No. / Serial No. and No Calibration specified.

#### 3.4.3 TEST PROCEDURE

a. Harmonic Current Test:

Test was performed according to the procedures specified in Clause 5.0 of IEC555-2 and/or Sub-clause 6.2 of IEC/EN 61000-3-2 depend on which standard adopted for compliance measurement.

b. Fluctuation and Flickers Test:

Tests was performed according to the Test Conditions/Assessment of Voltage Fluctuations specified in Clause 5.0/6.0 of IEC555-3 and/or Clause 6.0/4.0 of IEC/EN 61000-3-3 depend on which standard adopted for compliance measurement.

c. All types of harmonic current and/or voltage fluctuation in this report are assessed by direct measurement using flicker-meter.

d. For the actual test configuration, please refer to the related Item –EUT Test Photos.

#### 3.4.4 DEVIATION FROM TEST STANDARD

No deviation

### 3.4.5 TEST SETUP

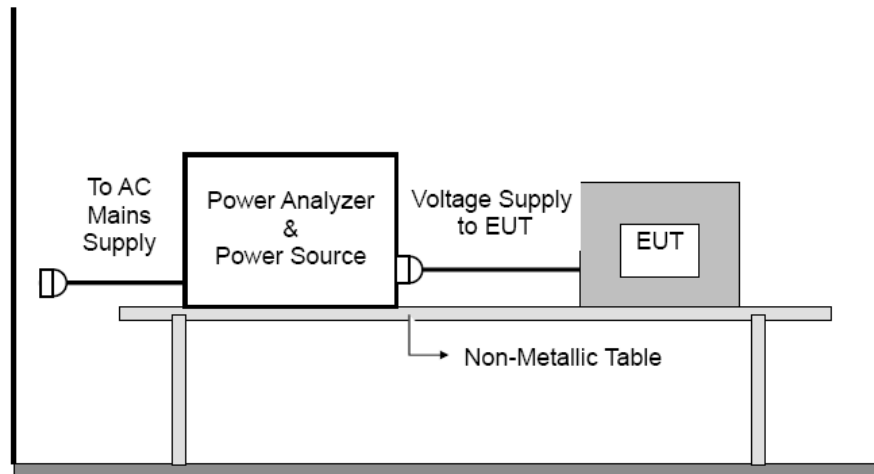

### 3.4.6 EUT OPERATING CONDITIONS

The EUT tested system was configured as the statements of 3.1.6 Unless otherwise a special operating condition is specified in the follows during the testing.

### 3.4.7 TEST RESULTS

According to EN61000-3-3 Clause 6, for voltage changes caused by manual switching, equipment is deemed to comply without further testing if the maximum r.m.s input current (including inrush current) evaluated over each 10 ms half-period between zero-crossings does not exceed 20A, and the supply current after inrush is within a variation band of 1.5A.



#### 4. IMMUNITY TEST

##### 4.1 STANDARD COMPLIANCE/SERVRITY LEVEL/CRITERIA

Tests Standard No.	Test Specification	Test Mode Test Ports	Perform. Criteria	Remark
1. ESD IEC/EN 61000-4-2	8KV air discharge 4KV contact discharge	Direct Mode	B	PASS
	4KV HCP discharge 4KV VCP discharge	Indirect Mode	B	PASS
2. RS IEC/EN 61000-4-3	80 MHz to 1000 MHz 3V/m(rms), 1 KHz, 80%, AM modulated	Enclosure	A	PASS
3. EFT/Burst IEC/EN 61000-4-4	1.0KV(peak) 5/50ns Tr/Th 5KHz Repetition Freq.	AC Power Port	B	PASS
	0.5 KV(peak) 5/50ns Tr/Th 5KHz Repetition Freq.	CTL/Signal Data Line Port	B	N/A
4. Surges IEC/EN 61000-4-5	1 KV(5P/5N) 1.2/50(8/20) Tr/Th us	L-N	B	PASS
	2 KV(5P/5N) 1.2/50(8/20) Tr/Th us	L-PE N-PE	B	N/A
5 Injected Current IEC/EN 61000-4-6	0.15 MHz to 80 MHz 3V(rms), 1KHz 80%, AM Modulated 150Ω source impedance	CTL/Signal Port	A	N/A
	0.15 MHz to 80 MHz 3V(rms), 1KHz 80%, AM Modulated 150Ω source impedance	AC Power Port	A	PASS
	0.15 MHz to 80 MHz 3V(rms), 1KHz 80%, AM Modulated 150Ω source impedance	DC Power Port	A	N/A
6. Power Frequency Magnetic Field IEC/EN 61000-4-8	50 Hz, 1A/m	Enclosure	A	PASS
7. Volt. Interruptions Volt. Dips IEC/EN 61000-4-11	Voltage dip > 95% / 30% Interruption > 95%	AC Power Port	B / C C	PASS See Remark(2)

\* Remark:

- (1) "N/A": denotes test is not applicable in this Test Report.
- (2) Voltage dip: >95% reduction – Performance Criteria **B**  
 Voltage dip: 30% reduction – Performance Criteria **C**  
 Voltage Interruption: >95% reduction – Performance Criteria **C**

#### 4.2 GENERAL PERFORMANCE CRITERIA

According to **EN55024: 2010+A1:2015** standard, the general performance criteria as following:

<b>Criterion A</b>	The equipment shall continue to operate as intended without operator intervention. No degradation of performance or loss of function is allowed below a performance level specified by the manufacturer when the equipment is used as intended. The performance level may be replaced by a permissible loss of performance. If the minimum performance level or the permissible performance loss is not specified by the manufacturer, then either of these may be derived from the product description and documentation, and by what the user product description and documentation, and by what the user may reasonably expect from the equipment if used as intended.
<b>Criterion B</b>	After the test, the equipment shall continue to operate as intended without operator Intervention. No degradation of performance or loss of function is allowed, after the application of the phenomenon below a performance level specified by the manufacturer, when the equipment is used as intended. The performance level may be replaced by a permissible loss of performance. During the test, degradation of performance is allowed. However, no change of operating state if stored data allowed to persist after the test. If the minimum performance level (or the permissible performance loss) is not specified by the manufacturer, then either of these may be derived from the product description and documentation, and by what the user may reasonably expect from the equipment if used as intended.
<b>Criterion C</b>	Loss of function is allowed, provided the function is self-recoverable, or can be restored by the operation of the controls by the user in accordance with the manufacturer's instructions. Functions, and/or information stored in non-volatile memory, or protected by a battery backup, shall not be lost.

#### 4.3 GENERAL PERFORMANCE CRITERIA TEST SETUP

The EUT tested system was configured as the statements of **3.1.6** Unless otherwise a special operating condition is specified in the follows during the testing.

#### 4.4 ESD TESTING

##### 4.4.1 TEST SPECIFICATION

<b>Basic Standard:</b>	IEC/EN 61000-4-2
<b>Discharge Impedance:</b>	330 ohm / 150 pF
<b>Required Performance</b>	B
<b>Discharge Voltage:</b>	Air Discharge: 2kV/4kV/8kV (Direct) Contact Discharge: 2kV/4kV (Direct/Indirect)
<b>Polarity:</b>	Positive & Negative
<b>Number of Discharge:</b>	Air Discharge: min. 20 times at each test point Contact Discharge: min. 200 times in total
<b>Discharge Mode:</b>	Contact and Air
<b>Discharge Period:</b>	1 second minimum

##### 4.4.2 MEASUREMENT INSTRUMENTS

Item	Kind of Equipment	Manufacturer	Type No.	Serial No.	Calibrated until
1	ESD Simulator	Prima	ESD61002B	PR13012530	2018-06-15

Remark: " N/A " denotes No Model No. / Serial No. and No Calibration specified.

##### 4.4.3 TEST PROCEDURE

The test generator necessary to perform direct and indirect application of discharges to the EUT in the following manner:

- a. Contact discharge was applied to conductive surfaces and coupling planes of the EUT.
 

During the test, it was performed with single discharges. For the single discharge time between successive single discharges was at least 1 second. The EUT shall be exposed to at least 200 discharges, 100 each at negative and positive polarity, at a minimum of four test points. One of the test points shall be subjected to at least 50 indirect discharges to the center of the front edge of the horizontal coupling plane. The remaining three test points shall each receive at least 50 direct contact discharges.

If no direct contact test points are available, then at least 200 indirect discharges shall be applied in the indirect mode. Test shall be performed at a maximum repetition rate of one discharge per second.

Vertical Coupling Plane (VCP):  
The coupling plane, of dimensions 0.5m x 0.5m, is placed parallel to, and positioned at a distance 0.1m from, the EUT, with the Discharge Electrode touching the coupling plane.  
The four faces of the EUT will be performed with electrostatic discharge.

Horizontal Coupling Plane (HCP):  
The coupling plane is placed under to the EUT. The generator shall be positioned vertically at a distance of 0.1m from the EUT, with the Discharge Electrode touching the coupling plane.  
The four faces of the EUT will be performed with electrostatic discharge.
- b. Air discharges at insulation surfaces of the EUT.
 

It was at least ten single discharges with positive and negative at the same selected point.
- c. For the actual test configuration, please refer to the related Item –EUT Test Photos.

**4.4.4 DEVIATION FROM TEST STANDARD**

No deviation

**4.4.5 TEST SETUP**

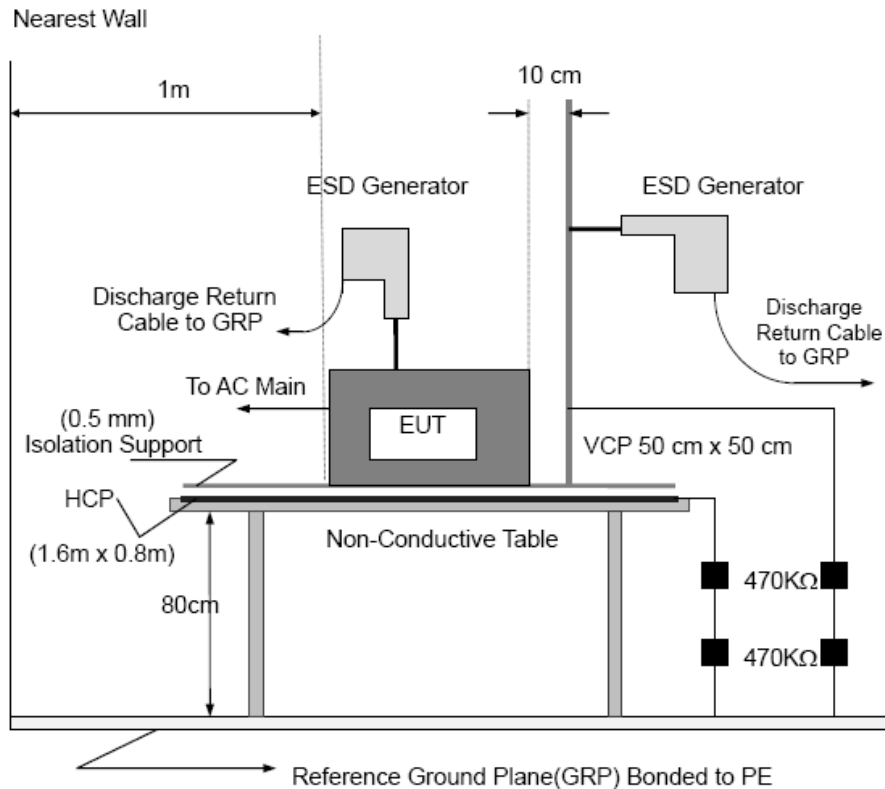

Note:

**TABLE-TOP EQUIPMENT**

The configuration consisted of a wooden table 0.8 meters high standing on the Ground Reference Plane. The GRP consisted of a sheet of aluminum at least 0.25mm thick, and 2.5 meters square connected to the protective grounding system. A Horizontal Coupling Plane (1.6m x 0.8m) was placed on the table and attached to the GRP by means of a cable with 940k total impedance. The equipment under test, was installed in a representative system as described in section 7 of IEC /EN 61000-4-2, and its cables were placed on the HCP and isolated by an insulating support of 0.5mm thickness. A distance of 1-meter minimum was provided between the EUT and the walls of the laboratory and any other metallic structure.

**FLOOR-STANDING EQUIPMENT**

The equipment under test was installed in a representative system as described in section 7 of IEC/EN 61000-4-2, and its cables were isolated from the Ground Reference Plane by an insulating support of 0.1-meter thickness. The GRP consisted of a sheet of aluminum that is at least 0.25mm thick, and 2.5meters square connected to the protective grounding system and extended at least 0.5 meters from the EUT on all sides.

**4.4.6 TEST RESULTS**

Mode	Air Discharge								Contact Discharge							
	2KV		4KV		8KV		12KV		2KV		4KV		6KV		8KV	
Location	P	N	P	N	P	N	P	N	P	N	P	N	P	N	P	N
1	--	--	A	A	A	A	--	--	--	--	--	--	--	--	--	--
2	--	--	--	--	--	--	--	--	A	A	A	A	--	--	--	--
3	-	--	--	--	--	--	--	--	--	--	--	--	--	--	--	--
4	--	--	--	--	--	--	--	--	--	--	--	--	--	--	--	--
5	--	--	--	--	--	--	--	--	--	--	--	--	--	--	--	--
6	-	--	--	--	--	--	--	--	--	--	--	--	--	--	--	--
7	--	--	--	--	--	--	--	--	--	--	--	--	--	--	--	--
8	--	--	--	--	-	--	--	--	--	--	--	--	--	--	--	--
9	--	--	--	--	-	--	--	--	--	--	--	--	--	--	--	--
Criteria	<b>B</b>								<b>B</b>							
Result	<b>A</b>								<b>A</b>							
Judgment	<b>PASS</b>								<b>PASS</b>							

Mode	HCP Discharge								VCP Discharge							
	2KV		4KV		6KV		8KV		2KV		4KV		6KV		8KV	
Location	P	N	P	N	P	N	P	N	P	N	P	N	P	N	P	N
1	-	--	A	A	--	--	--	--	-	--	A	A	--	--	--	--
2	--	--	A	A	--	--	--	--	--	--	A	A	--	--	--	--
3	--	--	A	A	-	--	--	--	--	--	A	A	-	--	--	--
4	-	--	A	A	--	--	--	--	-	--	A	A	--	--	--	--
Criteria	<b>B</b>								<b>B</b>							
Result	<b>A</b>								<b>A</b>							
Judgment	<b>PASS</b>								<b>PASS</b>							

Note:

- 1) P/N denotes the Positive/Negative polarity of the output voltage.
- 2) Test condition:  
 Direct discharges: Minimum 50 times (Positive/Negative) at each point.    Air discharges / Indirect (HCP/VCP): Minimum 20 times (Positive/Negative) at each point.
- 3) Test location(s) in which discharge (Air and contact discharge) to be described as following
- 4) The Indirect (HCP/VCP) discharges description of test point as following:  
 1.left side 2.right side 3.front side 4.rear side
- 5) N/A - denotes test is not applicable in this test report
- 7) Criteria B: The EUT function loss during the test, but self-recoverable after the test.

Test location description:

No	Description	No	Description
1	Slots                      4points	4	
2	Output port                1point	5	
3		6	

## 4.5 RS TESTING2

### 4.5.1 TEST SPECIFICATION

<b>Basic Standard:</b>	IEC/EN 61000-4-3
<b>Required Performance</b>	A
<b>Frequency Range:</b>	80 MHz - 1000 MHz
<b>Field Strength:</b>	3 V/m
<b>Modulation:</b>	1kHz Sine Wave, 80%, AM Modulation
<b>Frequency Step:</b>	1 % of fundamental
<b>Polarity of Antenna:</b>	Horizontal and Vertical
<b>Test Distance:</b>	3 m
<b>Antenna Height:</b>	1.5 m
<b>Dwell Time:</b>	at least 3 seconds

### 4.5.2 MEASUREMENT INSTRUMENTS

Item	Kind of Equipment	Manufacturer	Type No.	Serial No.	Calibrated until
1	Signal Generator	R&S	SMT 06	832080/007	2017-06-05
2	Power Amplifier(RS)	M2S	AC8113-800/25 0A	9904-113	2017-06-05
3	Antenna(500W)	MESS-ELEKTRONIK	VULB9161	4022	2017-06-05

Remark: " N/A" denotes No Model No. / Serial No. and No Calibration specified.

### 4.5.3 TEST PROCEDURE

The EUT and support equipment, which are placed on a table that is 0.8 meter above ground and the testing was performed in a fully-anechoic chamber.

The testing distance from antenna to the EUT was 3 meters.

The other condition as following manner:

- a. The field strength level was 3V/m.
- b. The frequency range is swept from 80 MHz to 1000 MHz, with the signal 80%amplitude modulated with a 1kHz sine wave. The rate of sweep did not exceed 1.5x 10<sup>-3</sup> decade/s. Where the frequency range is swept incrementally, the step size was 1% of fundamental.
- c. The dwell time at each frequency shall be not less than the time necessary for the EUT to be able to respond.
- d. The test was performed with the EUT exposed to both vertically and horizontally polarized fields on each of the four sides.
- e. For the actual test configuration, please refer to the related Item –EUT Test Photos.

### 4.5.4 DEVIATION FROM TEST STANDARD

No deviation

#### 4.5.5 TEST SETUP

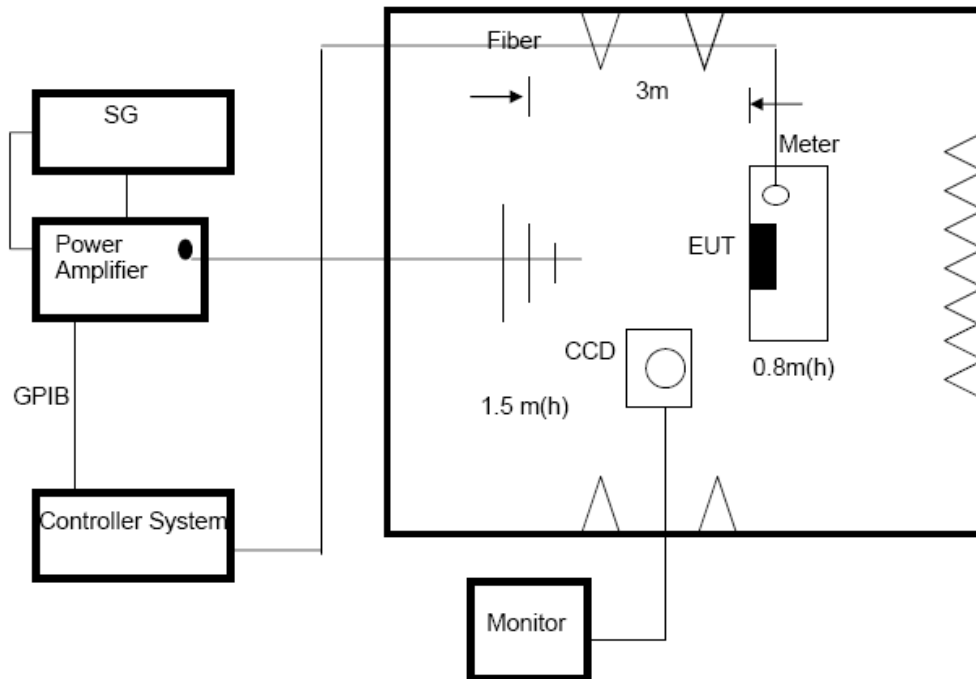

Note:

##### TABLE-TOP EQUIPMENT

The EUT installed in a representative system as described in section 7 of IEC/EN 61000-4-3 was placed on a non-conductive table 0.8 meters in height. The system under test was connected to the power and signal wire according to relevant installation instructions.

##### FLOOR-STANDING EQUIPMENT

The EUT installed in a representative system as described in section 7 of IEC/EN 61000-4-3 was placed on a non-conductive wood support 0.1 meters in height. The system under test was connected to the power and signal wire according to relevant installation instructions.

**4.5.6 TEST RESULTS**

Frequency Range (MHz)	Polarity of Antenna	R.F. Field Strength	Azimuth	Perform. Criteria	Results	Judgment
80MHz - 1000MHz	H / V	3 V/m (rms) AM Modulated 1000Hz, 80%	Front	<b>A</b>	<b>A</b>	<b>PASS</b>
			Rear			
			Left			
			Right			

Note:

- 1) H/V denotes the Horizontal/Vertical polarity of Antenna.
- 2) N/A - denotes test is not applicable in this test report.
- 3) Criteria A: There was no change operated with initial operating during the test.
- 4) Criteria B: The EUT function loss during the test, but self-recoverable after the test.
- 5) Criteria C: The system shut down during the test.



**4.6 EFT/BURST TESTING**

**4.6.1 TEST SPECIFICATION**

<b>Basic Standard:</b>	IEC/EN 61000-4-4
<b>Required Performance</b>	B
<b>Test Voltage:</b>	Power Line: $\pm 1$ kV
<b>Polarity:</b>	Positive & Negative
<b>Impulse Frequency:</b>	5 kHz
<b>Impulse Wave shape :</b>	5/50 ns
<b>Burst Duration:</b>	15 ms
<b>Burst Period:</b>	300 ms
<b>Test Duration:</b>	Not less than 1 min.

**4.6.2 MEASUREMENT INSTRUMENTS**

Item	Kind of Equipment	Manufacturer	Type No.	Serial No.	Calibrated until
1	Electrical Intelligent Transient Generator	Everfine	EMS61000-4B	G114921CA1341115	2018-06-19

Remark: " N/A" denotes No Model No. / Serial No. and No Calibration specified.

**4.6.3 TEST PROCEDURE**

The EUT and support equipment, are placed on a table that is 0.8 meter above a metal ground plane measured 1m\*1m min. and 0.65mm thick min.

The other condition as following manner:

- a. The length of power cord between the coupling device and the EUT should not exceed 1 meter.
- b. Both positive and negative polarity discharges were applied.
- c. The duration time of each test sequential was 1 minute
- d. For the actual test configuration, please refer to the related Item –EUT Test Photos.

**4.6.4 DEVIATION FROM TEST STANDARD**

No deviation

### 4.6.5 TEST SETUP

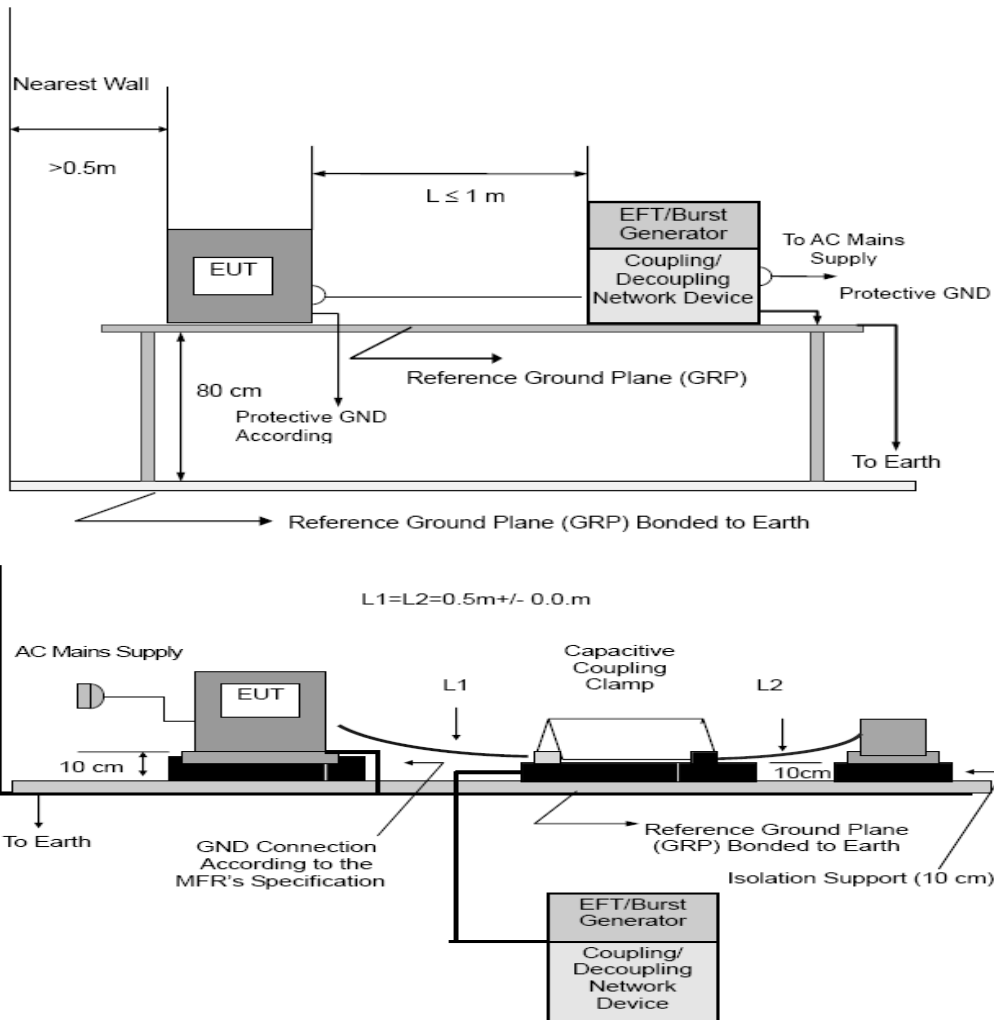

Note:

#### TABLE-TOP EQUIPMENT

The configuration consisted of a wooden table (0.8m high) standing on the Ground Reference Plane. The GRP consisted of a sheet of aluminum (at least 0.25mm thick and 2.5m square) connected to the protective grounding system. A minimum distance of 0.5m was provided between the EUT and the walls of the laboratory or any other metallic structure.

#### FLOOR-STANDING EQUIPMENT

The EUT installed in a representative system as described in section 7 of IEC/EN 61000-4-4 and its cables, were isolated from the Ground Reference Plane by an insulating support that is 0.1-meter thick. The GRP consisted of a sheet of aluminum (at least 0.25mm thick and 2.5m square) connected to the protective grounding system.

**4.6.6 TEST RESULTS**

Mode	AC Power Line		DC Power Line		Signal/Control Line	
Test Level	1KV		0.5KV		0.5KV	
Port(s)	Polarity	Results	Polarity	Results	Polarity	Results
Line (L)	P	A	P		P	
	N	A	N		N	
Neutral (N)	P	A	P		P	
	N	A	N		N	
Ground (PE)	P		P		P	
	N		N		N	
Signal/Control Line	P		P		P	
	N		N		N	
Criteria	<b>B</b>		<b>B</b>		<b>B</b>	
Result	<b>A</b>		<b>--</b>		<b>--</b>	
Judgment	<b>PASS</b>		<b>N/A</b>		<b>N/A</b>	

- 1) P/N denotes the Positive/Negative polarity of the output voltage.
- 2) N/A - denotes test is not applicable in this test report
- 3) Criteria A: There was no change operated with initial operating during the test.
- 4) Criteria B: The EUT function loss during the test, but self-recoverable after the test.
- 5) Criteria C: The system shut down during the test.

#### 4.7 SURGE TESTING

##### 4.7.1 TEST SPECIFICATION

<b>Basic Standard:</b>	IEC/EN 61000-4-5
<b>Required Performance</b>	B
<b>Wave-Shape:</b>	Combination Wave 1.2/50 us Open Circuit Voltage 8 /20 us Short Circuit Current
<b>Test Voltage:</b>	Power Line: 0.5 kV, 1 kV, 2 kV
<b>Surge Input/Output:</b>	L-N, L-PE, N-PE
<b>Generator Source:</b>	2 ohm between networks
<b>Impedance:</b>	12 ohm between network and ground
<b>Polarity:</b>	Positive/Negative
<b>Phase Angle:</b>	0 /90/180/270
<b>Pulse Repetition Rate:</b>	1 time / min. (maximum)
<b>Number of Tests:</b>	5 positive and 5 negative at selected points

##### 4.7.2 MEASUREMENT INSTRUMENTS

Item	Kind of Equipment	Manufacturer	Type No.	Serial No.	Calibrated until
1	EMC Immunity Test System	Prima	SUG61005CX	PR13065597	2018-06-11

Remark: " N/A" denotes No Model No. / Serial No. and No Calibration specified.

##### 4.7.3 TEST PROCEDURE

a. For EUT SWITCHING AC/DC ADAPTOR:

The surge is to be applied to the EUT SWITCHING AC/DC ADAPTOR terminals via the capacitive coupling network. Decoupling networks are required in order to avoid possible adverse effects on equipment not under test that may be powered by the same lines, and to provide sufficient decoupling impedance to the surge wave. The power cord between the EUT and the coupling/decoupling networks shall be 2meters in length (or shorter).

b. For test applied to unshielded unsymmetrically operated interconnection lines of EUT:

The surge is applied to the lines via the capacitive coupling. The coupling /decoupling networks shall not influence the specified functional conditions of the EUT. The interconnection line between the EUT and the coupling/decoupling networks shall be 2 meters in length (or shorter).

c. For test applied to unshielded symmetrically operated interconnection /telecommunication lines of EUT:

The surge is applied to the lines via gas arrestors coupling. Test levels below the ignition point of the coupling arrester cannot be specified. The interconnection line between the EUT and the coupling/decoupling networks shall be 2 meters in length (or shorter).

d. For the actual test configuration, please refer to the related Item –EUT Test Photos.

#### 4.7.4 DEVIATION FROM TEST STANDARD

No deviation

#### 4.7.5 TEST SETUP

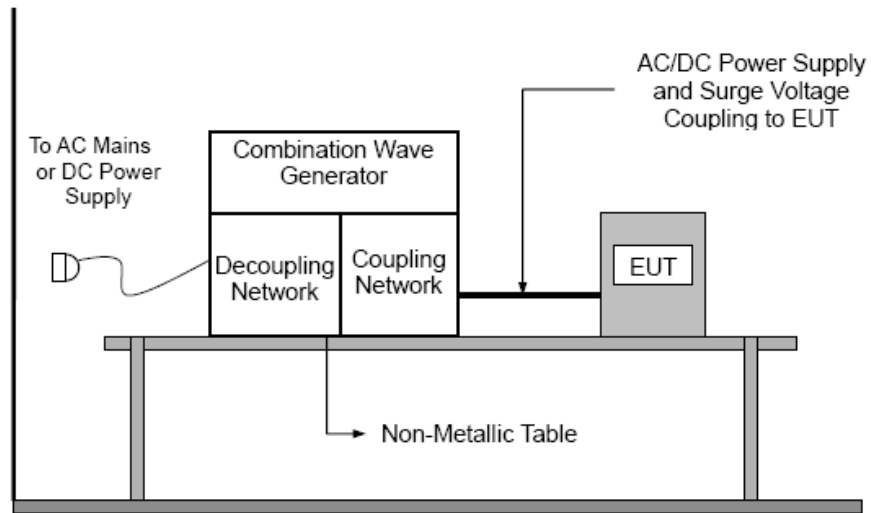

**4.7.6 TEST RESULTS**

Wave Form EUT Ports Tested	1.2/50(8/20) us						Criteria	Judgment
	Polarity	Phase	Voltage					
			0.5kV	1kV	1.5kV	2kV		
L - N	+/-	0°		A			B	PASS
	+/-	90°		A				
	+/-	180°		A				
	+/-	270°		A				
L - PE	+/-	0°					B	N/A
	+/-	90°						
	+/-	180°						
	+/-	270°						
N - PE	+/-	0°					B	N/A
	+/-	90°						
	+/-	180°						
	+/-	270°						
Signal Line (N/A)	+/-	0°					B	N/A
	+/-	90°						
	+/-	180°						
	+/-	270°						
Signal Line (N/A)	+/-	0°					B	N/A
	+/-	90°						
	+/-	180°						
	+/-	270°						

Note:

1) N/A - denotes test is not applicable in this Test Report

**4.8 INJECTION CURRENT TESTING**

**4.8.1 TEST SPECIFICATION**

<b>Basic Standard:</b>	IEC/EN 61000-4-6
<b>Required Performance</b>	A
<b>Frequency Range:</b>	0.15 MHz - 80 MHz
<b>Field Strength:</b>	3 Vr.m.s.
<b>Modulation:</b>	1kHz Sine Wave, 80%, AM Modulation
<b>Frequency Step:</b>	1 % of fundamental
<b>Dwell Time:</b>	at least 3 seconds

**4.8.2 MEASUREMENT INSTRUMENTS**

Item	Kind of Equipment	Manufacturer	Type No.	Serial No.	Calibrated until
1	Signal Generator	IFR	2023A	202301/368	2018-06-05
2	Power Amplifier(CS)	M2S	A0122-250	9902-111	2018-06-05
3	CDN	MEB	M3	13389	2018-06-05

Remark: " N/A" denotes No Model No. / Serial No. and No Calibration specified.

**4.8.3 TEST PROCEDURE**

The EUT and support equipment, are placed on a table that is 0.8 meter above a metal ground plane measured 1m\*1m min. and 0.65mm thick min.

The other condition as following manner:

- a. The field strength level was 3V.
- b. The frequency range is swept from 150 KHz to 80 MHz, with the signal 80%amplitude modulated with a 1kHz sine wave. The rate of sweep did not exceed  $1.5 \times 10^{-3}$  decade/s. Where the frequency range is swept incrementally, the step size was 1% of fundamental.
- c. The dwell time at each frequency shall be not less than the time necessary for the EUT to be able to respond.
- d. For the actual test configuration, please refer to the related Item –EUT Test Photos.

**4.8.4 DEVIATION FROM TEST STANDARD**

No deviation

**4.8.5 TEST SETUP**

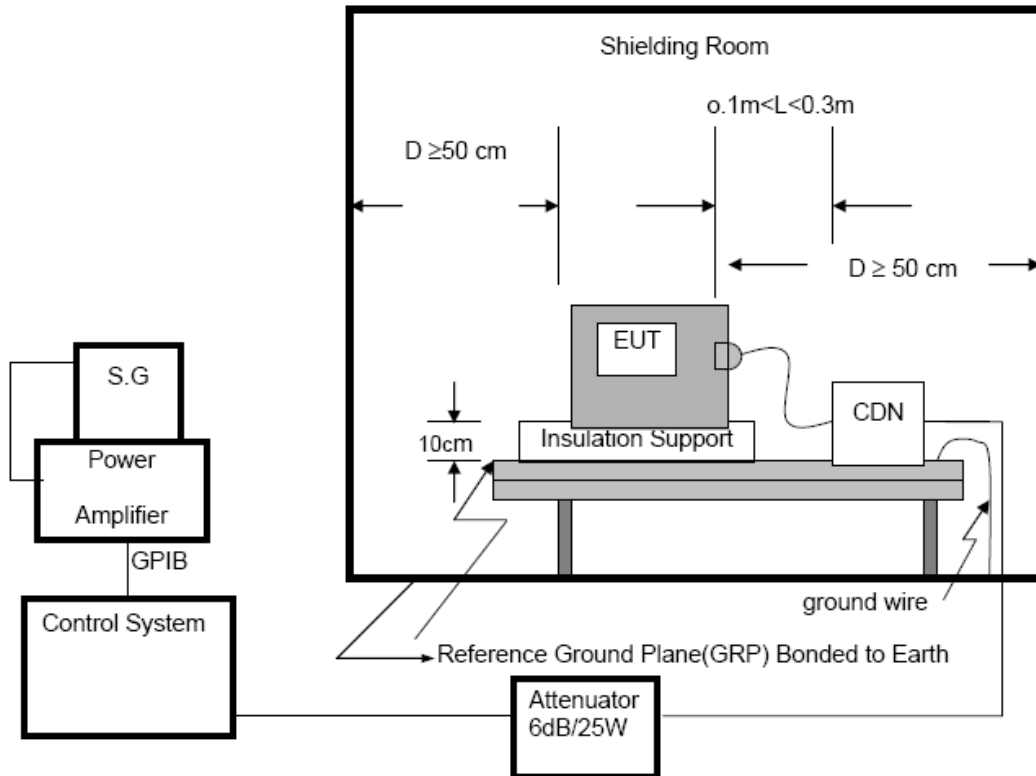

For the actual test configuration, please refer to the related Item –EUT Test Photos.

**NOTE:**

**FLOOR-STANDING EQUIPMENT**

The equipment to be tested is placed on an insulating support of 0.1 meters height above a ground reference plane. All relevant cables shall be provided with the appropriate coupling and decoupling devices at a distance between 0.1 meters and 0.3 meters from the projected geometry of the EUT on the ground reference plane.



**4.8.6 TEST RESULTS**

Test Ports (Mode)	Freq. Range MHz)	Field Strength	Perform. Criteria	Results	Judgment
Input/ Output AC. Power Port	0.15 ---80	3V(rms) AM Modulated 1000Hz, 80%	<b>A</b>	<b>A</b>	<b>PASS</b>
Input/ Output DC. Power Port	0.15 --- 80		<b>A</b>	--	<b>N/A</b>
Signal Line ( N/A )	0.15 --- 80		<b>A</b>	--	<b>N/A</b>
Signal Line ( N/A )	0.15 --- 80		<b>A</b>	--	<b>N/A</b>

Note:

- 1) N/A - denotes test is not applicable in this Test Report.

#### 4.9 VOLTAGE INTERRUPTION/DIPS TESTING

##### 4.9.1 TEST SPECIFICATION

<b>Basic Standard:</b>	IEC/EN 61000-4-11
<b>Required Performance:</b>	B (For >95% Voltage Dips) C (For 30% Voltage Dips) C (For >95% Voltage Interruptions)
<b>Test Duration Time:</b>	Minimum three test events in sequence
<b>Interval between Event:</b>	Minimum ten seconds
<b>Phase Angle:</b>	0°
<b>Test Cycle:</b>	3 times

##### 4.9.2 MEASUREMENT INSTRUMENTS

Item	Kind of Equipment	Manufacturer	Type No.	Serial No.	Calibrated until
1	Voltage Dips And Interruptions Generator	Everfine	EMS61000-11K	G113317CA8341 117	2017-06-04

Remark: " N/A" denotes No Model No. / Serial No. and No Calibration specified.

##### 4.9.3 TEST PROCEDURE

The EUT shall be tested for each selected combination of test levels and duration with a sequence of three dips/interruptions with intervals of 10 s minimum (between each test event). Each representative mode of operation shall be tested. Abrupt changes in supply voltage shall occur at zero crossings of the voltage waveform.

##### 4.9.4 DEVIATION FROM TEST STANDARD

No deviation

#### 4.9.5 TEST SETUP

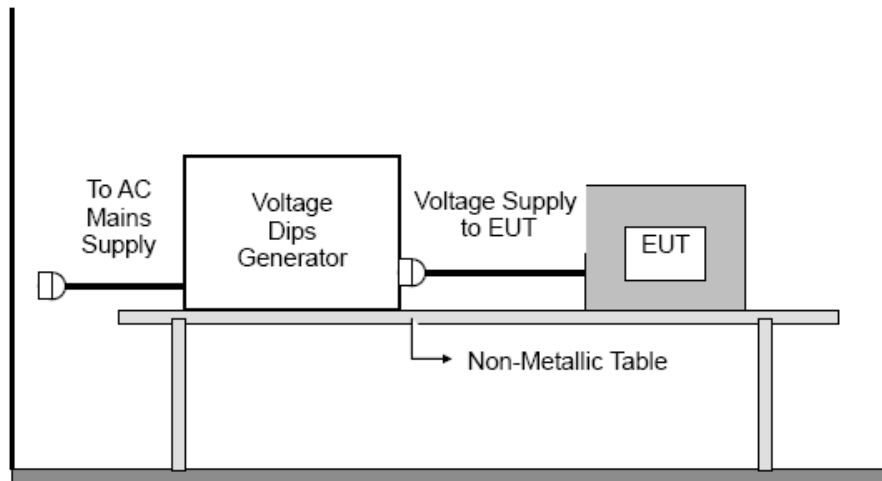

For the actual test configuration, please refer to the related Item –EUT Test Photos.

#### 4.9.6 TEST RESULTS

Voltage Reduction	Periods	Perform Criteria	Results	Judgment
Voltage dip >95%	0.5	<b>B</b>	<b>A</b>	<b>PASS</b>
Voltage dip 30%	25	<b>C</b>	<b>A</b>	<b>PASS</b>
Interruption >95%	250	<b>C</b>	<b>C</b>	<b>PASS</b>

Note:

- 1) N/A - denotes test is not applicable in this test report.

**4.10 POWER-FREQUENCY MAGNETIC FILDS**

**4.10.1 MEASUREMENT INSTRUMENTS**

Item	Kind of Equipment	Manufacturer	Type No.	Serial No.	Calibrated until
1	PFMF Generator	EMPEK	PMF8010	14202	2018-06-05

Remark: " N/A" denotes No Model No. / Serial No. and No Calibration specified.

**4.10.2 TEST LEVEL AND PERFORMANCE CRITERION**

Level	Magnetic Field Strength A/m	Performance criterion
1	1	A

Performance criteria A description: During and after the test the EUT shall continue to operate as intended without operator intervention. No degradation of performance or loss of function is allowed below a minimum performance level specified by the manufacturer when the EUT is used as intended

**4.10.3 TEST PROCEDURE**

The EUT shall be subjected to the test magnetic field by using the induction coil of standard dimensions (1m\*1m) and shown in Section 13.3 The induction coil shall then be rotated by 90 ein order to expose the EUT to the test field with different orientations. .

**4.10.4 DEVIATION FROM TEST STANDARD**

No deviation

**4.10.5 TEST SETUP**

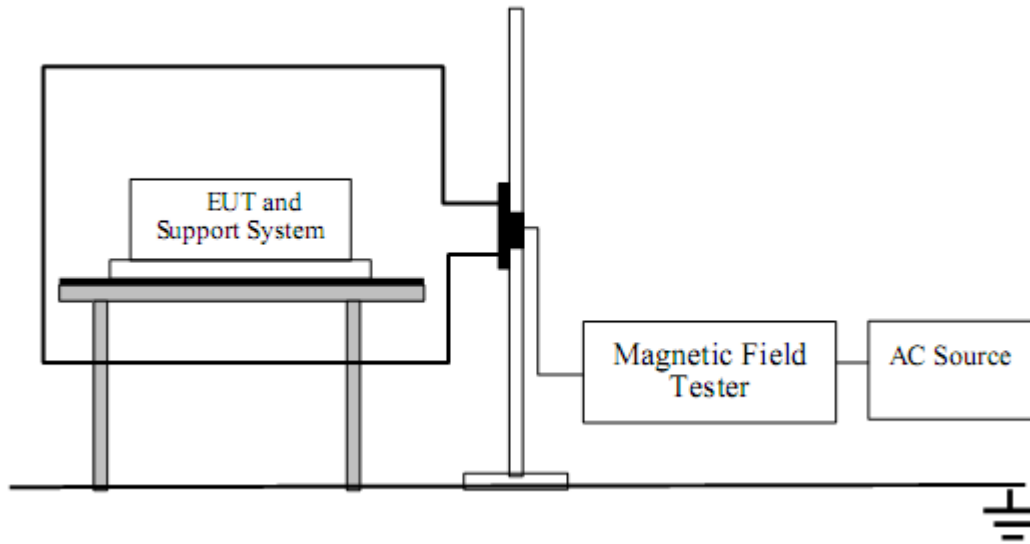

**4.10.6 TEST RESULTS**

Operation Mode	Test Level	Testing Duration	Coil Orientation	Required	Observation	Result (Pass/Fail)
Full Load	1A/m	5 min / coil	X	A	A	Pass
	1A/m	5 min / coil	Y	A	A	Pass
	1A/m	5 min / coil	Z	A	A	Pass

Note:

Operation as intend, no loss of function during test and after test

**5. ATTACHMENT**  
5.1 EUT TEST PHOTO

**Conducted Measurement Photo**



**Radiated Measurement Photo**

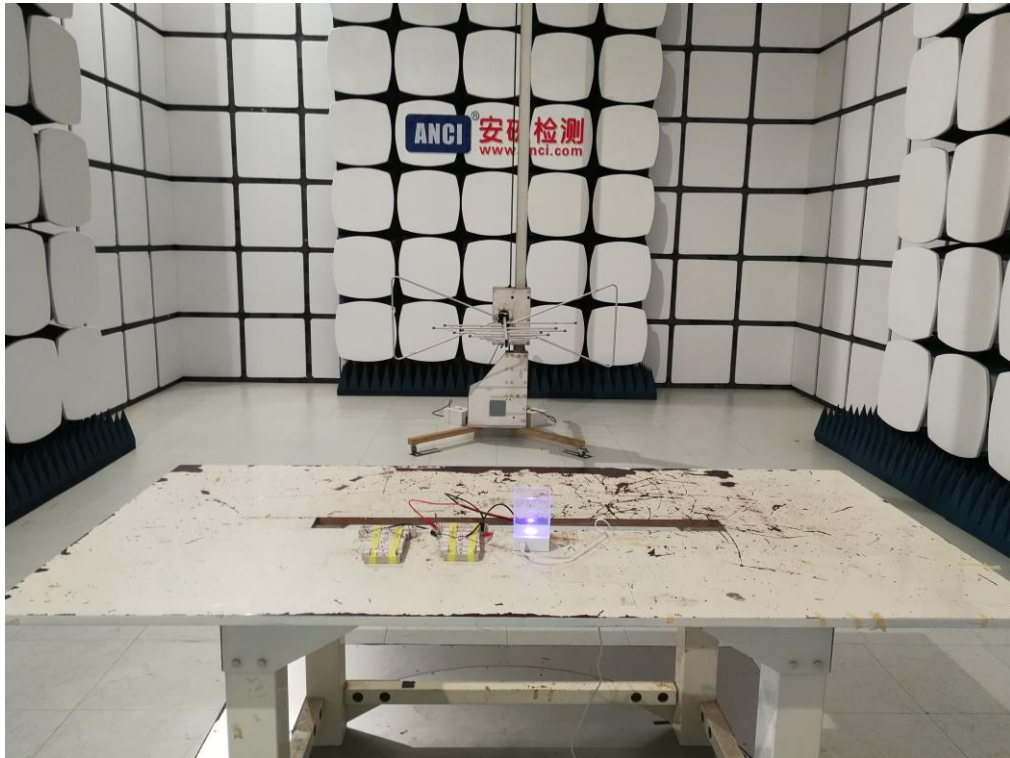

### ESD Measurement Photos

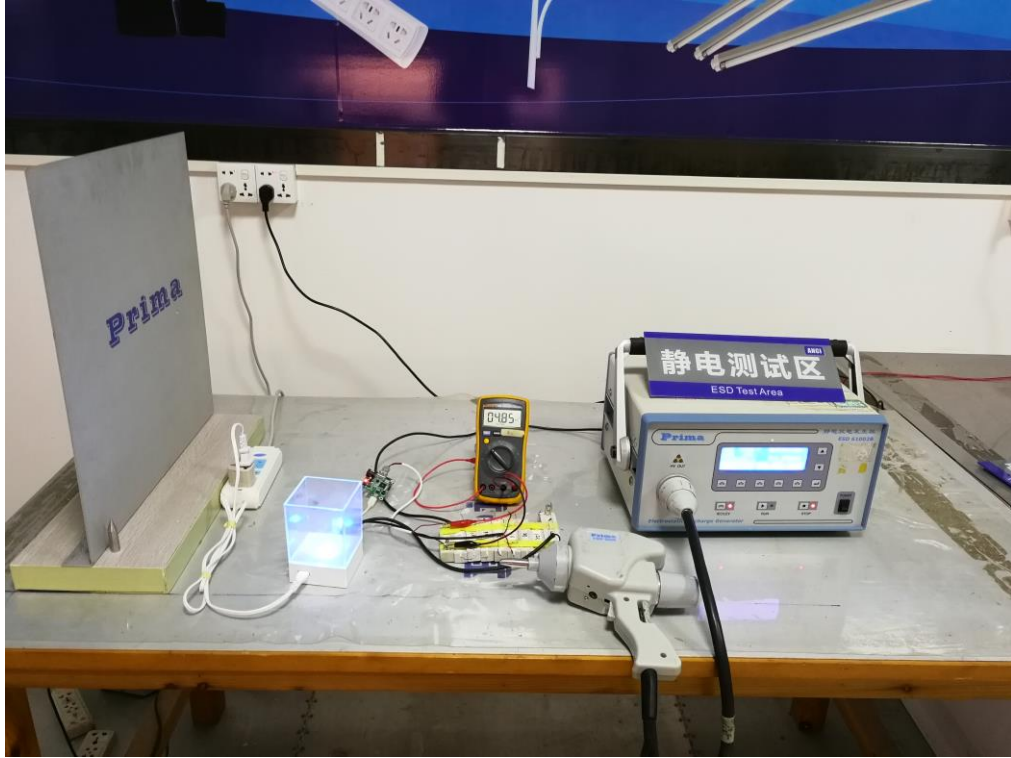

### Surge Measurement Photos





**EFT Measurement Photos**



**Dips Measurement Photos**

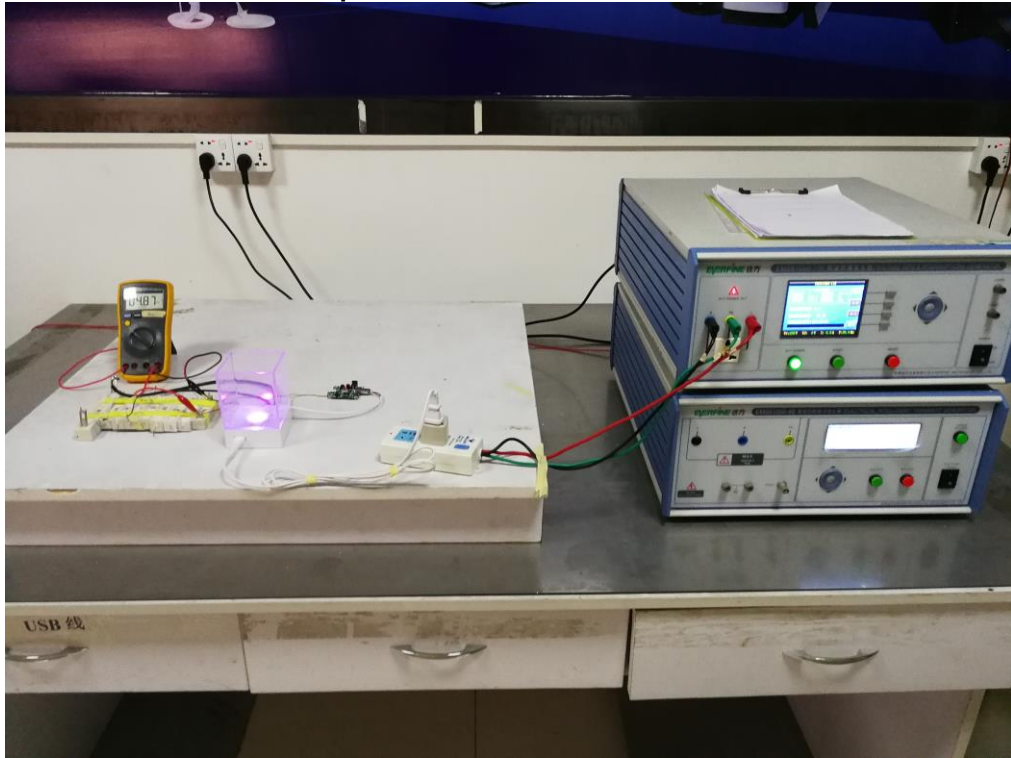



### 5.2 EUT PHOTO

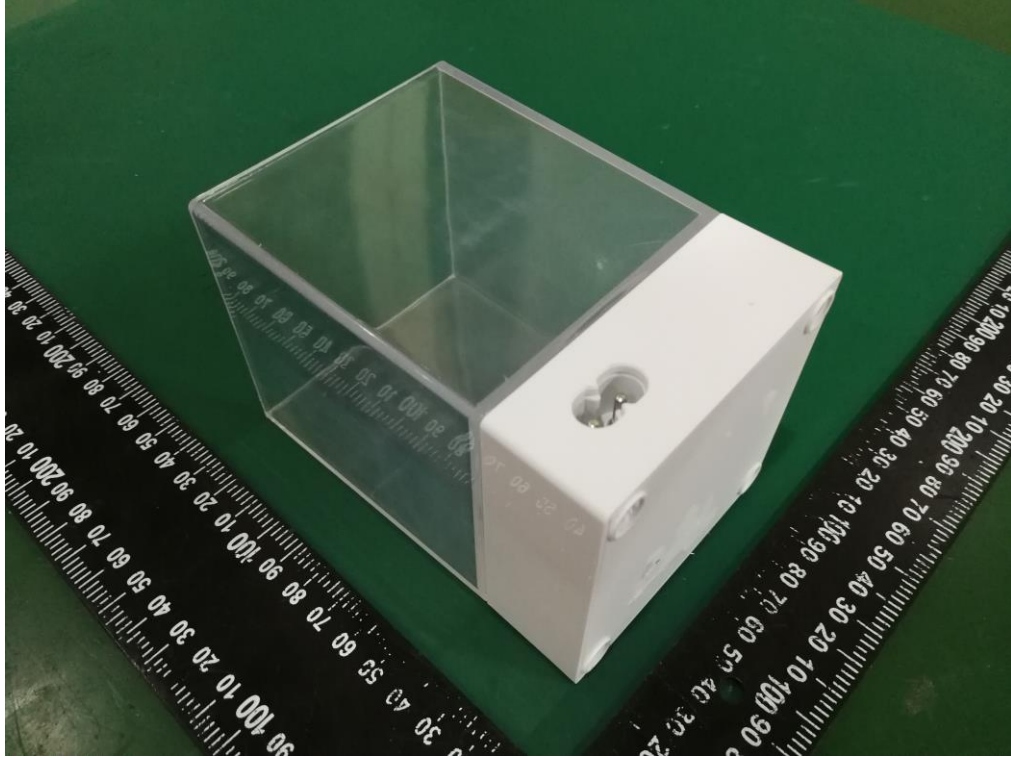

Figure 1.Overall view of unit

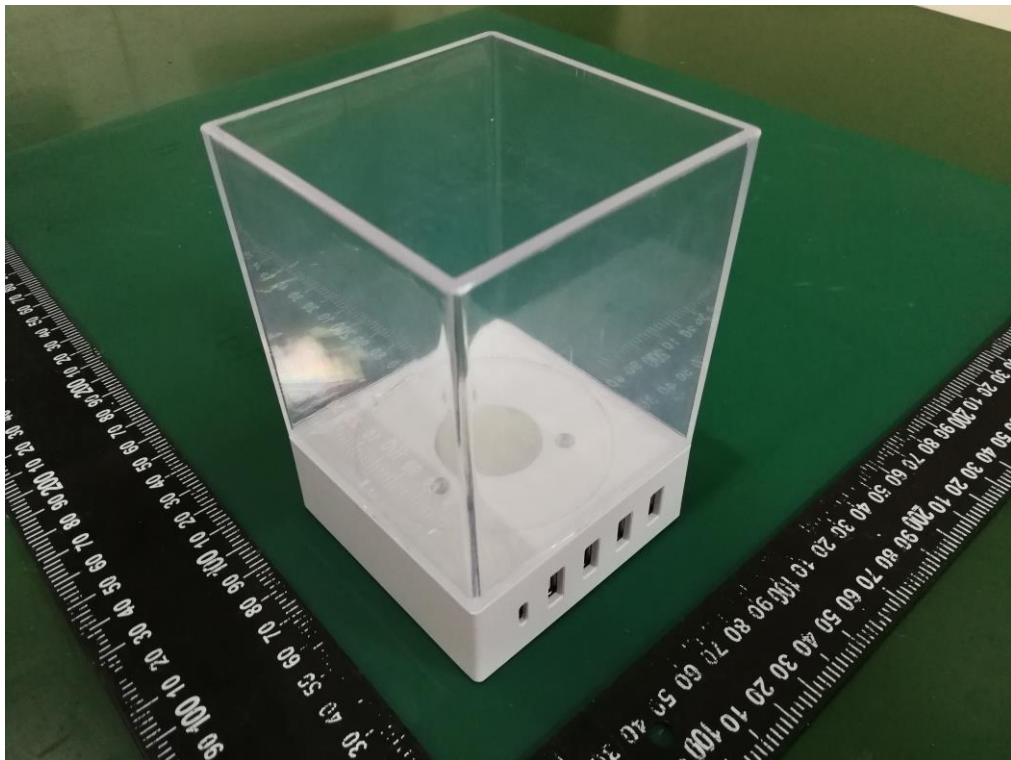

Figure 2.Overall view of unit

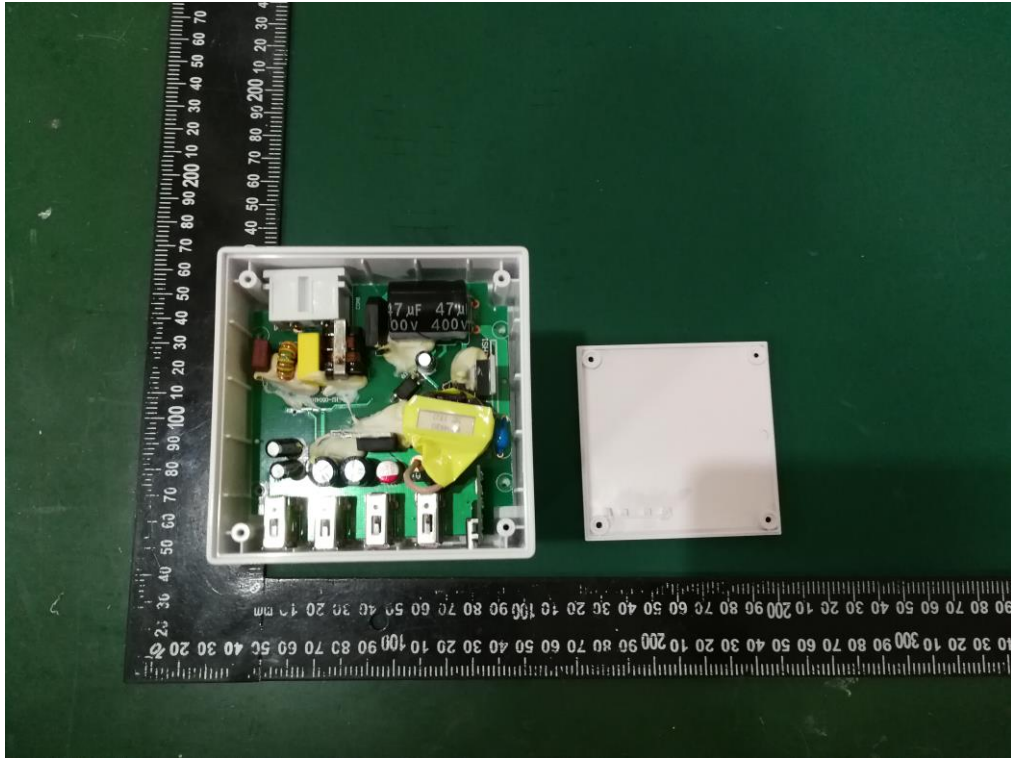

Figure 3. Inside view of unit

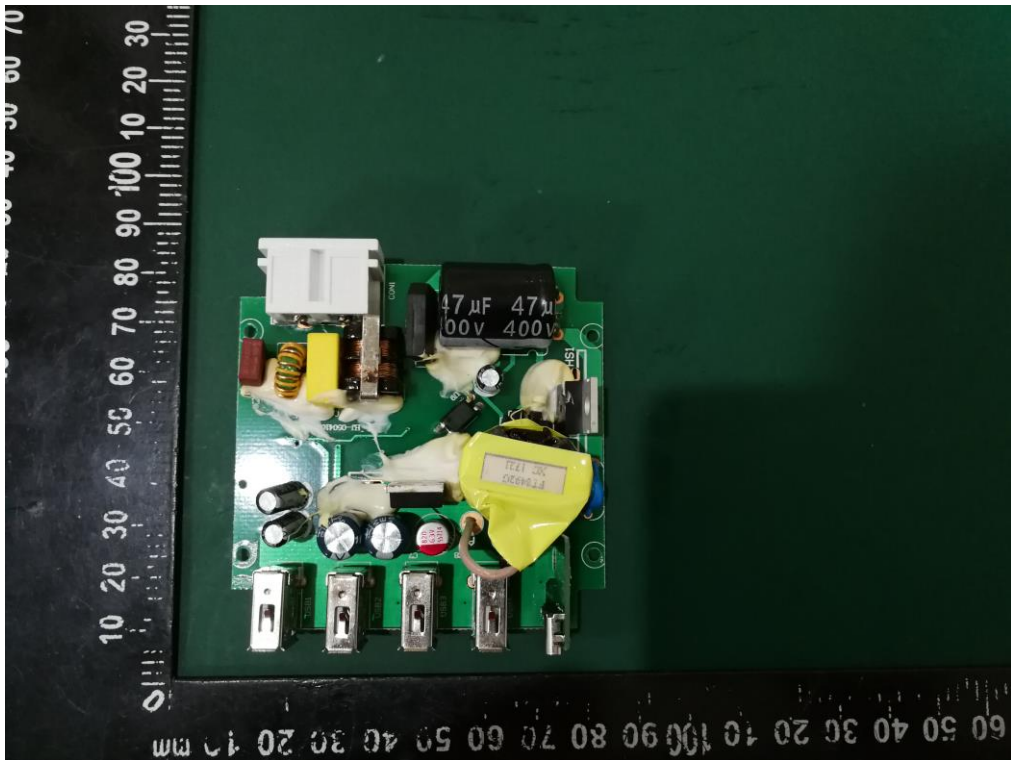

Figure 4. Top view of PCB

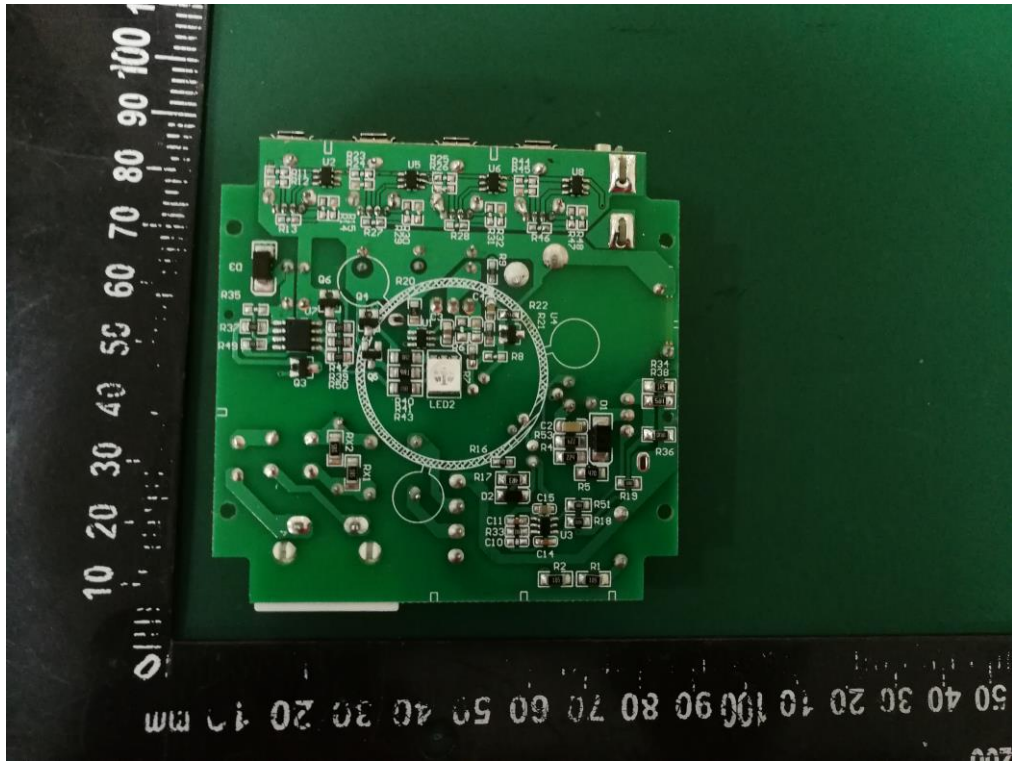

Figure 5. Bottom view of PCB