

EN 301 489 EMC TEST REPORT

FOR

Applicant	:	Protech Electronics & Technology Limited
Address	:	12A floor, Building 12, ZHX Innovation Industrial City, No. 12th, Ganli 6 Road, Jihua Street, Longgang District, Shenzhen, China
Equipment under Test	:	Wireless Extender
Model No.	:	PET100W, PET100W-R
Trade Mark	:	/
Manufacturer	:	Protech Electronics & Technology Limited
Address	:	12A floor, Building 12, ZHX Innovation Industrial City, No. 12th, Ganli 6 Road, Jihua Street, Longgang District, Shenzhen, China

Issued By: Dongguan Dongdian Testing Service Co., Ltd.

Add: No. 17, Zongbu Road 2, Songshan Lake Sci&Tech, Industry Park, Dongguan City, Guangdong Province, China, 523808

Tel: +86-0769-38826678, **E-mail:** ddt@dgddt.com, **http://**www.dgddt.com

TABLE OF CONTENTS

	Test report declares.....	3
1.	Summary of test results.....	7
2.	General test information	10
2.1.	Description of EUT	10
2.2.	Accessories of EUT	10
2.3.	Assistant equipment used for test.....	10
2.4.	Block diagram EUT configuration for test	11
2.5.	Decision of final test mode.....	11
2.6.	Deviations of test standard	11
2.7.	Test environment conditions.....	11
2.8.	Test laboratory.....	11
2.9.	Measurement uncertainty	12
3.	Conducted Emission Test Report (mains power port)	13
3.1.	General information	13
3.2.	Test Equipment	13
3.3.	Reference Standard	13
3.4.	Block Diagram of Test Setup.....	13
3.5.	Limits	13
3.6.	Test Procedure	14
3.7.	Test Result	14
3.8.	Test photo.....	19
4.	Radiated emissions test	20
4.1.	General information	20
4.2.	Test Equipment	20
4.3.	Reference Standard	20
4.4.	Block diagram of test setup	21
4.5.	Radiated disturbance limit of class B.....	22
4.6.	Test Procedure	22
4.7.	Test result.....	22
4.8.	Test photo.....	25
5.	Harmonic current and Voltage fluctuations & flicker test report	27
5.1.	General information	27
5.2.	Test Equipment	27
5.3.	Test Standard	27
5.4.	Block diagram of test setup	27
5.5.	Harmonic current limits	28
5.6.	Voltage fluctuations & flicker Limit	29
5.7.	Test Procedure	29

5.8.	Test result.....	29
5.9.	Test photo.....	32
6.	Electrostatic discharge test report	33
6.1.	General information	33
6.2.	Test Equipment	33
6.3.	Test and Reference Standards.....	33
6.4.	Block diagram of test setup	33
6.5.	Test levels and performance criterion.....	33
6.6.	Test Procedure	34
6.7.	Test result.....	34
6.8.	Test photo.....	35
7.	Continuous radio frequency disturbances	36
7.1.	General information	36
7.2.	Test Equipment	36
7.3.	Test and Reference Standards.....	36
7.4.	Block diagram of test setup	36
7.5.	Test levels and performance criterion.....	37
7.6.	Test Procedure	37
7.7.	Test result.....	37
7.8.	Test photo.....	38
8.	Electrical fast transients (EFT) test report	39
8.1.	General information	39
8.2.	Test Equipment	39
8.3.	Test and Reference Standards.....	39
8.4.	Block diagram of test setup	39
8.5.	Test levels and performance criterion.....	39
8.6.	Test Procedure	40
8.7.	Test result.....	40
8.8.	Test photo.....	41
9.	Surges test report	42
9.1.	General information	42
9.2.	Test Equipment	42
9.3.	Test and Reference Standards.....	42
9.4.	Block diagram of test setup	42
9.5.	Test levels and performance criterion.....	42
9.6.	Test Procedure	43
9.7.	Test result.....	43
9.8.	Test photo.....	44
10.	Continuous conducted disturbances.....	45
10.1.	General information	45

10.2.	Test Equipment	45
10.3.	Test and Reference Standards	45
10.4.	Block diagram of test setup	45
10.5.	Test levels and performance criterion.....	45
10.6.	Test Procedure	46
10.7.	Test result.....	46
10.8.	Test photo.....	46
11.	Voltage dips and interruptions	47
11.1.	General information	47
11.2.	Test Equipment	47
11.3.	Test and Reference Standards	47
11.4.	Block diagram of test setup	47
11.5.	Test levels and performance criterion.....	47
11.6.	Test Procedure	48
11.7.	Test result.....	48
11.8.	Test photo.....	48
12.	Photos of the EUT	49

TEST REPORT DECLARE

Applicant	:	Protech Electronics & Technology Limited
Address	:	12A floor, Building 12, ZHX Innovation Industrial City, No. 12th, Ganli 6 Road, Jihua Street, Longgang District, Shenzhen, China
Equipment under Test	:	Wireless Extender
Model No.	:	PET100W, PET100W-R
Trade mark	:	/
Manufacturer	:	Protech Electronics & Technology Limited
Address	:	12A floor, Building 12, ZHX Innovation Industrial City, No. 12th, Ganli 6 Road, Jihua Street, Longgang District, Shenzhen, China

Test Standard Used:

Draft EN 301 489-1 V2.2.1: 2019-03; Final draft EN 301 489-3 V2.1.1 (2017-03);
 EN 55032-2015+AC-2016; EN 55035-2017
 EN 61000-3-2:2014; EN 61000-3-3:2013

We Declare:

The equipment described above is tested by Dongguan Dongdian Testing Service Co., Ltd. and in the configuration tested the equipment complied with the standards specified above. The test results are contained in this test report and Dongguan Dongdian Testing Service Co., Ltd. is assumed of full responsibility for the accuracy and completeness of these tests.

After test and evaluation, our opinion is that the equipment in accordance with above standards about the electromagnetic compatibility requirements of Article 3.1(b) of Directive 2014/53/EU.

Report No:	DDT-R19080620-1E1		
Date of Receipt:	Aug. 15, 2019	Date of Test:	Aug. 15, 2019 ~ Sep. 05, 2019

Prepared By:**Approved By:**

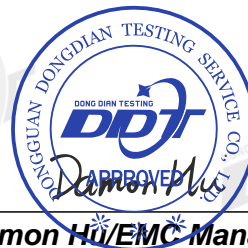
Eddie Liu/Engineer**Damon Hu/EMC Manager**

Note: This report applies to above tested sample only. This report shall not be reproduced in parts without written approval of Dongguan Dongdian Testing Service Co., Ltd.

Revision history

Rev.	Revisions	Issue Date	Revised By
---	Initial issue	Sep. 11, 2019	

1. Summary of test results

Description of Test Item	According Standard	Results
EMC emission		
Radiated emission	Draft EN 301 489-1 V2.2.1: 2019-03 Final draft EN 301 489-3 V2.1.1 EN 55032-2015+AC-2016	PASS
Conducted emission(DC power port)	Draft EN 301 489-1 V2.2.1: 2019-03 Final draft EN 301 489-3 V2.1.1 EN 55032-2015+AC-2016	N/A
Conducted emission(AC mains port)	Draft EN 301 489-1 V2.2.1: 2019-03 Final draft EN 301 489-3 V2.1.1 EN 55032-2015+AC-2016	PASS
Harmonic current emissions	EN 61000-3-2:2014	N/A
Voltage fluctuation and flicker	EN 61000-3-3:2013	PASS
Immunity		
Electrostatic discharge	Draft EN 301 489-1 V2.2.1: 2019-03 Final draft EN 301 489-3 V2.1.1 EN 55035-2017	PASS
RF electromagnetic field (80MHz to 6GHz)	Draft EN 301 489-1 V2.2.1: 2019-03 Final draft EN 301 489-3 V2.1.1 EN 55035-2017	PASS
Electrical fast transients	Draft EN 301 489-1 V2.2.1: 2019-03 Final draft EN 301 489-3 V2.1.1 EN 55035-2017	PASS
Conducted disturbance	Draft EN 301 489-1 V2.2.1: 2019-03 Final draft EN 301 489-3 V2.1.1 EN 55035-2017	PASS
Voltage dips and interruptions	Draft EN 301 489-1 V2.2.1: 2019-03 Final draft EN 301 489-3 V2.1.1 EN 55035-2017	PASS
Surge	Draft EN 301 489-1 V2.2.1: 2019-03 Final draft EN 301 489-3 V2.1.1 EN 55035-2017	PASS
Note: N/A is an abbreviation for Not Applicable.		

Remark: Performance criteria:

Criteria	During test	After test
A	Shall operate as intended. May show degradation of performance (see note 1). Shall be no loss of function. Shall be no unintentional transmissions.	Shall operate as intended. Shall be no degradation of performance (see note 2). Shall be no loss of function. Shall be no loss of stored data or user programmable functions.
B	May show loss of function (one or more). May show degradation of performance (see note 1). No unintentional transmissions.	Functions shall be self-recoverable. Shall operate as intended after recovering. Shall be no degradation of performance (see note 2). Shall be no loss of stored data or user programmable functions.
C	May be loss of function (one or more).	Functions shall be recoverable by the operator. Shall operate as intended after recovering. Shall be no degradation of performance (see note 2).
<p>NOTE 1: Degradation of performance during the test is understood as a degradation to a level not below a minimum performance level specified by the manufacturer for the use of the apparatus as intended. In some cases the specified minimum performance level may be replaced by a permissible degradation of performance. If the minimum performance level or the permissible performance degradation is not specified by the manufacturer then either of these may be derived from the product description and documentation (including leaflets and advertising) and what the user may reasonably expect from the apparatus if used as intended.</p> <p>NOTE 2: No degradation of performance after the test is understood as no degradation below a minimum performance level specified by the manufacturer for the use of the apparatus as intended. In some cases the specified minimum performance level may be replaced by a permissible degradation of performance. After the test no change of actual operating data or user retrievable data is allowed. If the minimum performance level or the permissible performance degradation is not specified by the manufacturer then either of these may be derived from the product description and documentation (including leaflets and advertising) and what the user may reasonably expect from the apparatus if used as intended.</p>		

Performance criteria for continuous phenomena applied to Transmitter (CT):

The performance criteria A shall apply.

Tests shall be repeated with the EUT in standby mode (if applicable) to ensure that unintentional transmission does not occur. In systems using acknowledgement signals, it is recognized that an ACKnowledgement (ACK) or Not ACKnowledgement (NACK) transmission may occur, and steps should be taken to ensure that any transmission resulting from the application of the test is correctly interpreted.

Performance criteria for Transient phenomena applied to Transmitters (TT):

The performance criteria B shall apply, except for voltage dips of 100 ms and voltage interruptions of 5 000 ms duration, for which performance criteria C shall apply.

Tests shall be repeated with the EUT in standby mode (if applicable) to ensure that unintentional transmission does not occur. In systems using acknowledgement signals, it is recognized that an acknowledgement (ACK) or not-acknowledgement (NACK) transmission may occur, and steps should be taken to ensure that any transmission resulting from the application of the test is correctly interpreted.

Performance criteria for Continuous phenomena applied to Receivers (CR):

The performance criteria A shall apply.

Where the EUT is a transceiver, under no circumstances, shall the transmitter operate unintentionally during the test. In systems using acknowledgement signals, it is recognized that an ACK or NACK transmission may occur, and steps should be taken to ensure that any transmission resulting from the application of the test is correctly interpreted.

Performance criteria for Transient phenomena applied to Receivers (TR)

The performance criteria B shall apply, except for voltage dips of 100 ms and voltage interruptions of 5 000 ms duration for which performance criteria C shall apply.

Where the EUT is a transceiver, under no circumstances, shall the transmitter operate unintentionally during the test. In systems using acknowledgement signals, it is recognized that an ACK or NACK transmission may occur, and steps should be taken to ensure that any transmission resulting from the application of the test is correctly interpreted.

2. General test information

2.1. Description of EUT

EUT* Name	: Wireless Extender
Model Number	: PET100W, PET100W-R
Model Differences	: PET100W-T is a transmitting signal equipment, PET100W-R is a receiving signal equipment.
EUT function description	: Please reference user manual of this device
Power supply	: DC 5V, powered by an external adapter
Hardware Version	: V1.1
Software Version	: V1.0.0.5
Radio Specification	: IEEE802.11a
Operation frequency	: 5765MHZ
Modulation	: IEEE 802.11a: OFDM (64QAM, 16QAM, QPSK, BPSK)
Transmitter rate	: IEEE 802.11a: 6, 9, 12, 18, 24, 36, 48, 54 Mbps
Antenna Type	: Dedicated SMA antenna, maximum PK gain: 5 dBi
Sample Type	: Series production

Note: EUT is the ab. of equipment under test.

2.2. Accessories of EUT

Description of Accessories	Manufacturer	Model number	Serial No.	Other
AC/DC adapter	Shenzhen Keyu Power Supply Technology Co., Ltd.	KA1201A-0502000 EU	N/A	Input: 100-240V~, 50/60Hz, 0.4A Max Output: DC 5V 2A

2.3. Assistant equipment used for test

Assistant equipment	Manufacturer	Model number	Description	other
Laptop	HP	HP ProBook 445 G6	5CD9112VSV	AC Adapter Mode: TPN-CA17, HP Part No.: L25299-002, Input: 100-240V, 50/60Hz, Output: DC 19.5V, 3.33A, 65W
HP Monitor	HP	S270n	6CM91901Q0	N/A
LCD Monitor	DELL	S2440Lb	CN-0N5XDC-74261-31E-0HFQ	AC/DC ADAPTER MF: DELTA ELECTRONICS INC. MODEL:ADP-400D B; AC Line: 1.8m long, unshielded no core, DC Line: 1.5m unshielded two cores
HP Monitor	HP	Z27n-G2	6CM7301JQ1	N/A
Honor box	HUAWEI	MediaQ M321	21530143458W7B044553	N/A
HDMI cable	N/A	N/A	N/A	Length: 1.5m, shield

2.4. Block diagram EUT configuration for test

For mode 1: Tx+ Rx mode

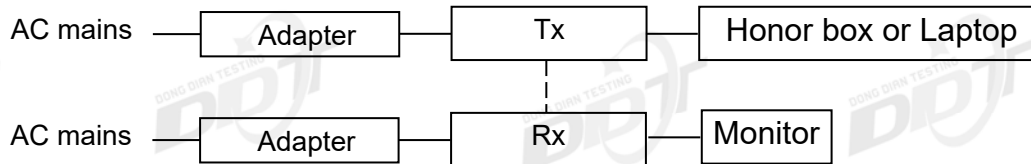

2.5. Decision of final test mode

According pre-test, the worst test modes decided as below and reported.

Emission	Conducted Emission (Mains Port)	mode 1: Tx+ Rx mode
	Radiated emission	mode 1: Tx+ Rx mode
	Voltage fluctuations & flicker	mode 1: Tx+ Rx mode
Immunity	Electrostatic discharge	mode 1: Tx+ Rx mode
	Continuous radio frequency disturbances	mode 1: Tx+ Rx mode
	Electrical fast transients	mode 1: Tx+ Rx mode
	Surges	mode 1: Tx+ Rx mode
	Continuous conducted disturbances	mode 1: Tx+ Rx mode
	Voltage dips and interruptions	mode 1: Tx+ Rx mode

2.6. Deviations of test standard

No Deviation.

2.7. Test environment conditions

During the measurement the environmental conditions were within the listed ranges:

Temperature range:	21-25°C
Humidity range:	40-75%
Pressure range:	86-106kPa

2.8. Test laboratory

Dongguan Dongdian Testing Service Co., Ltd.

Add: No. 17, Zongbu Road 2, Songshan Lake Sci&Tech, Industry Park, Dongguan City, Guangdong Province, China, 523808

Tel: +86-0769-38826678, <http://www.dgddt.com>, Email: ddt@dgddt.com

CNAS Accreditation No. L6451; A2LA Accreditation No. 3870.01

FCC Designation Number: CN1182; Test Firm Registration Number: 540522

Industry Canada site registration number: 10288A-1

2.9. Measurement uncertainty

Test Item	Uncertainty
Conducted disturbance at mains terminals	3.32dB (150kHz-30MHz)
Uncertainty for telecommunication port conduction emission test	AAN with aLCL = 55 ... 40 dB c: 3.64dB AAN with aLCL = 65 ... 50 dB c: 4.08dB AAN with aLCL = 75 ... 60 dB c: 4.56dB
Uncertainty for Radiation Emission test (30MHz-1GHz)	4.70 dB (Antenna Polarize: V) 4.84 dB (Antenna Polarize: H)
Uncertainty for Radiation disturbance test (1GHz to 6GHz)	4.10dB
Uncertainty for Flicker test	0.2%
Uncertainty for Harmonic test	5%
Temperature	0.4°C
Humidity	2%

Note: This uncertainty represents an expanded uncertainty expressed at approximately the 95% confidence level using a coverage factor of k=2.

3. Conducted Emission Test Report (mains power port)

3.1. General information

Project No.	: DDT-R19080620-1E1
Test and report Engineer	: KIVIN
Test and report Date	: Sep. 03, 2019

3.2. Test Equipment

Equipment	Manufacturer	Model No.	Serial No.	Last Cal.	Cal. Interval
Test Receiver	R&S	ESCI	100551	Oct. 12, 2018	1 Year
LISN 1	R&S	ENV216	101109	Oct. 12, 2018	1 Year
LISN 2	R&S	ESH2-Z5	100309	Oct. 12, 2018	1 Year
Pulse Limiter	R&S	ESH3-Z2	101242	Oct. 12, 2018	1 Year
CE Cable 1	HUBSER	ESU8/RF2	W10.01	Oct. 12, 2018	1 Year
Test software	Audix	E3	V 6.11111b	N/A	N/A

3.3. Reference Standard

Draft EN 301 489-1 V2.2.1: 2019-03; Final draft EN 301 489-3 V2.1.1 (2017-03);

3.4. Block Diagram of Test Setup

For table-top equipment

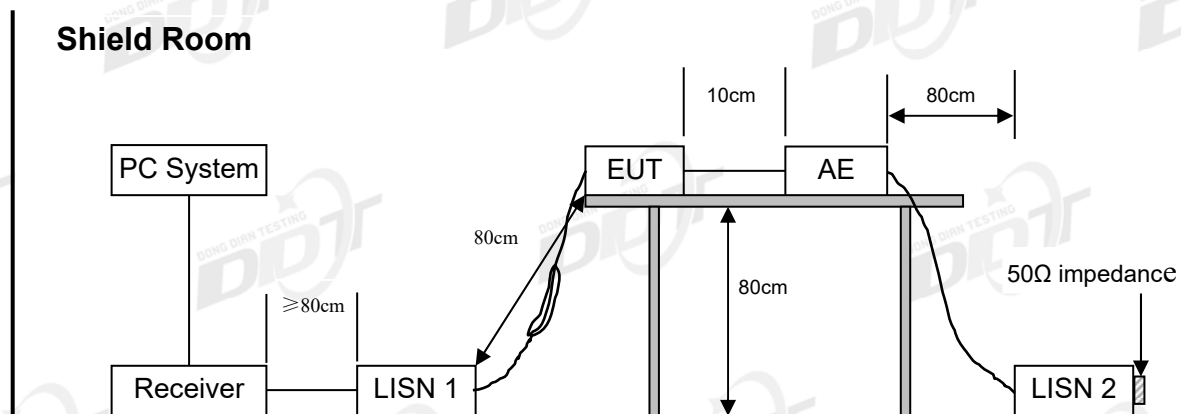

3.5. Limits

Class A

Frequency	Quasi-Peak Level dB(μ V)	Average Level dB(μ V)
150kHz ~ 500kHz	79	66
500kHz ~ 30MHz	73	60

Class B

Frequency	Quasi-Peak Level dB(μ V)	Average Level dB(μ V)
150kHz ~ 500kHz	66 ~ 56*	56 ~ 46*
500kHz ~ 5MHz	56	46
5MHz ~ 30MHz	60	50

Notes: 1. * Decreasing linearly with logarithm of frequency.

2. The lower limit shall apply at the transition frequencies.

3.6. Test Procedure

- (1) The EUT was placed on a non-metallic table, 80cm above the ground plane.
- (2) Setup the EUT and assistant equipment as shown in section 2.4 and 3.4
- (3) The EUT's power adapter was connected to the power mains through a line impedance stabilization network (L.I.S.N). which this provided a 50-ohm coupling impedance for the EUT (Please refer to the block diagram of the test setup and photographs). Both sides of power line were checked for maximum conducted disturbance. In order to find the maximum emission, the relative positions of equipment and all of the interface cables were changed according to EN 301489 on conducted disturbance emission test.
- (4) The bandwidth of test receiver is set at 9 KHz.
- (5) The frequency range from 150 KHz to 30MHz is checked.

3.7. Test Result

PASS. (See below detailed test result)

Note 1: All emissions not reported below are too low against the prescribed limits.

Note 2: "----" means Peak detection; "----" means Average detection.

TR-4-E-010 Conducted Emission Test Result

Test Site : DDT 1# Shield Room **D:\2019 report data\Q19080620-1E\20190903 CE.EM6**
Test Date : 2019-09-03 **Tested By** : KIVIN
EUT : Wireless Extender **Model Number** : PET100W
Power Supply : AC 230V/50Hz **Test Mode** : Tx mode
Condition : Temp:24.5°C,Humi:55.5%,Press:100.1kPa **LISN** : 2018 ENV216 2##/NEUTRAL
Memo :

Data: 6

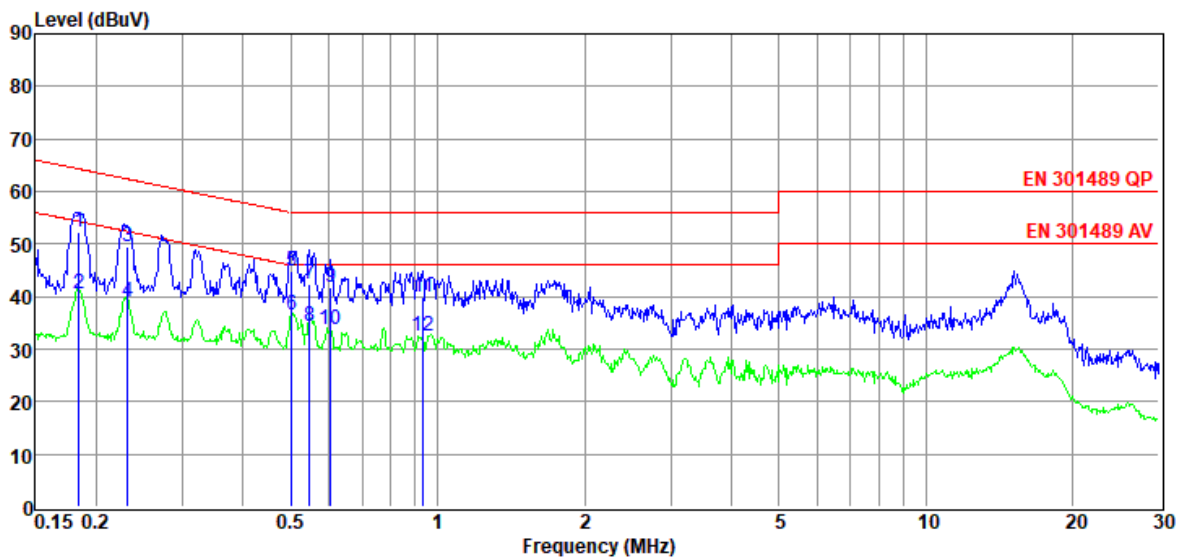

Item (Mark)	Freq. (MHz)	Read Level (dBμV)	LISN Factor (dB)	Cable Loss (dB)	Pulse Limiter Factor (dB)	Result Level (dBμV)	Limit Line (dBμV)	Over Limit (dB)	Detector	Phase
1	0.18	32.74	9.66	0.18	9.78	52.36	64.28	-11.92	QP	NEUTRAL
2	0.18	20.94	9.66	0.18	9.78	40.56	54.28	-13.72	Average	NEUTRAL
3	0.23	29.78	9.66	0.18	9.78	49.40	62.39	-12.99	QP	NEUTRAL
4	0.23	19.49	9.66	0.18	9.78	39.11	52.39	-13.28	Average	NEUTRAL
5	0.50	25.08	9.64	0.20	9.78	44.70	56.00	-11.30	QP	NEUTRAL
6	0.50	16.97	9.64	0.20	9.78	36.59	46.00	-9.41	Average	NEUTRAL
7	0.55	22.76	9.64	0.20	9.78	42.38	56.00	-13.62	QP	NEUTRAL
8	0.55	14.56	9.64	0.20	9.78	34.18	46.00	-11.82	Average	NEUTRAL
9	0.60	22.05	9.64	0.21	9.78	41.68	56.00	-14.32	QP	NEUTRAL
10	0.60	14.16	9.64	0.21	9.78	33.79	46.00	-12.21	Average	NEUTRAL
11	0.93	20.15	9.64	0.22	9.78	39.79	56.00	-16.21	QP	NEUTRAL
12	0.93	12.93	9.64	0.22	9.78	32.57	46.00	-13.43	Average	NEUTRAL

- Note: 1. Result Level = Read Level + LISN Factor + Pulse Limiter Factor + Cable loss.
 2. If QP Result complies with AV limit, AV Result is deemed to comply with AV limit.
 3. Test setup: RBW: 200 Hz (9 kHz—150 kHz), 9 kHz (150 kHz—30 MHz).
 4. Step size: 80Hz (0.009MHz-0.15MHz), 4 kHz (0.15MHz-30MHz), Scan time: auto.

TR-4-E-010 Conducted Emission Test Result

Test Site : DDT 1# Shield Room **D:\2019 report data\Q19080620-1E\20190903 CE.EM6**
Test Date : 2019-09-03 **Tested By** : KIVIN
EUT : Wireless Extender **Model Number** : PET100W
Power Supply : AC 230V/50Hz **Test Mode** : Tx mode
Condition : Temp:24.5°C,Humi:55.5%,Press:100.1kPa **LISN** : 2018 ENV216 2#/LINE
Memo :

Data: 8

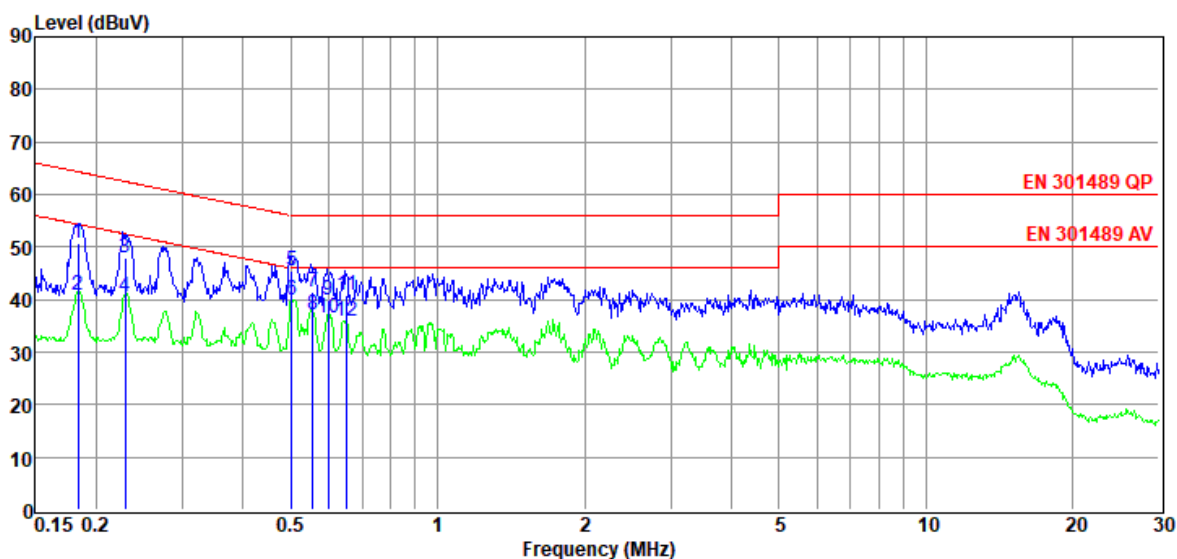

Item	Freq.	Read Level	LISN Factor	Cable Loss	Pulse Limiter Factor	Result Level	Limit Line	Over Limit	Detector	Phase
(Mark)	(MHz)	(dBμV)	(dB)	(dB)	(dB)	(dBμV)	(dBμV)	(dB)		
1	0.18	30.99	9.66	0.18	9.78	50.61	64.33	-13.72	QP	LINE
2	0.18	21.26	9.66	0.18	9.78	40.88	54.33	-13.45	Average	LINE
3	0.23	28.33	9.66	0.18	9.78	47.95	62.48	-14.53	QP	LINE
4	0.23	20.97	9.66	0.18	9.78	40.59	52.48	-11.89	Average	LINE
5	0.50	25.70	9.64	0.20	9.78	45.32	56.00	-10.68	QP	LINE
6	0.50	20.18	9.64	0.20	9.78	39.80	46.00	-6.20	Average	LINE
7	0.56	21.90	9.64	0.20	9.78	41.52	56.00	-14.48	QP	LINE
8	0.56	17.44	9.64	0.20	9.78	37.06	46.00	-8.94	Average	LINE
9	0.60	20.39	9.64	0.21	9.78	40.02	56.00	-15.98	QP	LINE
10	0.60	16.86	9.64	0.21	9.78	36.49	46.00	-9.51	Average	LINE
11	0.65	21.20	9.64	0.21	9.78	40.83	56.00	-15.17	QP	LINE
12	0.65	16.14	9.64	0.21	9.78	35.77	46.00	-10.23	Average	LINE

- Note: 1. Result Level = Read Level + LISN Factor + Pulse Limiter Factor + Cable loss.
 2. If QP Result complies with AV limit, AV Result is deemed to comply with AV limit.
 3. Test setup: RBW: 200 Hz (9 kHz—150 kHz), 9 kHz (150 kHz—30 MHz).
 4. Step size: 80Hz (0.009MHz-0.15MHz), 4 kHz (0.15MHz-30MHz), Scan time: auto.

TR-4-E-010 Conducted Emission Test Result

Test Site : DDT 1# Shield Room D:\2019 report data\Q19080620-1E\20190903 CE.EM6
Test Date : 2019-09-03 **Tested By** : KIVIN
EUT : Wireless Extender **Model Number** : PET100W
Power Supply : AC 230V/50Hz **Test Mode** : Rx mode
Condition : Temp:24.5°C,Humi:55.5%,Press:100.1kPa **LISN** : 2018 ENV216 2#/LINE
Memo :

Data: 10

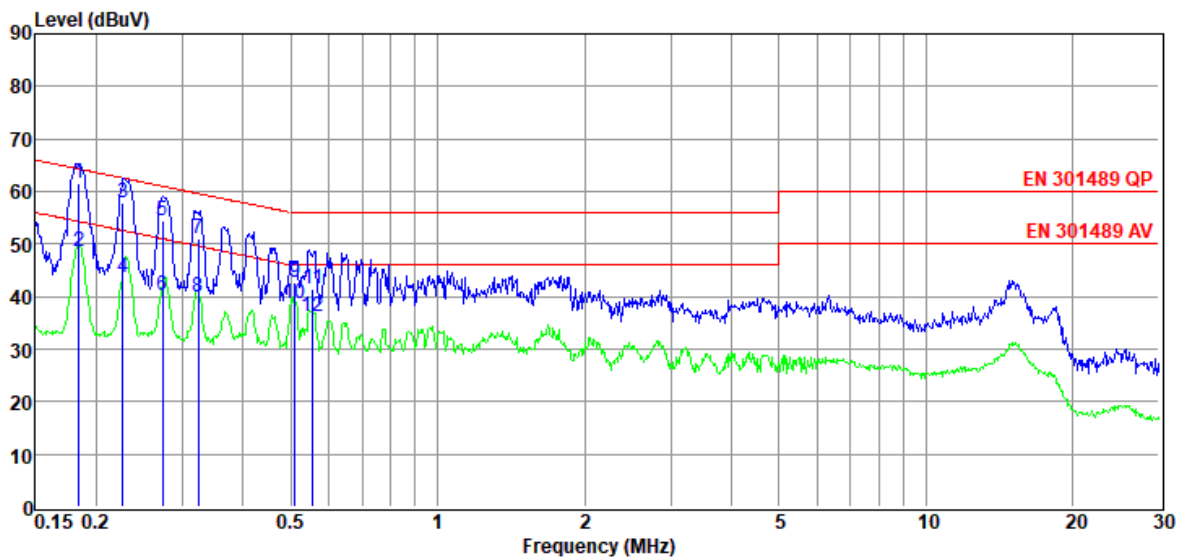

Item	Freq.	Read Level	LISN Factor	Cable Loss	Pulse Limiter Factor	Result Level	Limit Line	Over Limit	Detector	Phase
(Mark)	(MHz)	(dBμV)	(dB)	(dB)	(dB)	(dBμV)	(dBμV)	(dB)		
1	0.18	41.99	9.66	0.18	9.78	61.61	64.28	-2.67	QP	LINE
2	0.18	29.04	9.66	0.18	9.78	48.66	54.28	-5.62	Average	LINE
3	0.23	38.29	9.66	0.18	9.78	57.91	62.57	-4.66	QP	LINE
4	0.23	23.94	9.66	0.18	9.78	43.56	52.57	-9.01	Average	LINE
5	0.27	34.91	9.65	0.19	9.78	54.53	61.03	-6.50	QP	LINE
6	0.27	20.66	9.65	0.19	9.78	40.28	51.03	-10.75	Average	LINE
7	0.32	31.28	9.65	0.19	9.78	50.90	59.62	-8.72	QP	LINE
8	0.32	20.19	9.65	0.19	9.78	39.81	49.62	-9.81	Average	LINE
9	0.51	22.99	9.64	0.20	9.78	42.61	56.00	-13.39	QP	LINE
10	0.51	19.17	9.64	0.20	9.78	38.79	46.00	-7.21	Average	LINE
11	0.56	21.73	9.64	0.20	9.78	41.35	56.00	-14.65	QP	LINE
12	0.56	16.61	9.64	0.20	9.78	36.23	46.00	-9.77	Average	LINE

- Note: 1. Result Level = Read Level + LISN Factor + Pulse Limiter Factor + Cable loss.
 2. If QP Result complies with AV limit, AV Result is deemed to comply with AV limit.
 3. Test setup: RBW: 200 Hz (9 kHz—150 kHz), 9 kHz (150 kHz—30 MHz).
 4. Step size: 80Hz (0.009MHz-0.15MHz), 4 kHz (0.15MHz-30MHz), Scan time: auto.

TR-4-E-010 Conducted Emission Test Result

Test Site : DDT 1# Shield Room D:\2019 report data\Q19080620-1E\20190903 CE.EM6
Test Date : 2019-09-03 **Tested By** : KIVIN
EUT : Wireless Extender **Model Number** : PET100W
Power Supply : AC 230V/50Hz **Test Mode** : Rx mode
Condition : Temp:24.5°C,Humi:55.5%,Press:100.1kPa **LISN** : 2018 ENV216 2#/NEUTRAL
Memo :

Data: 12

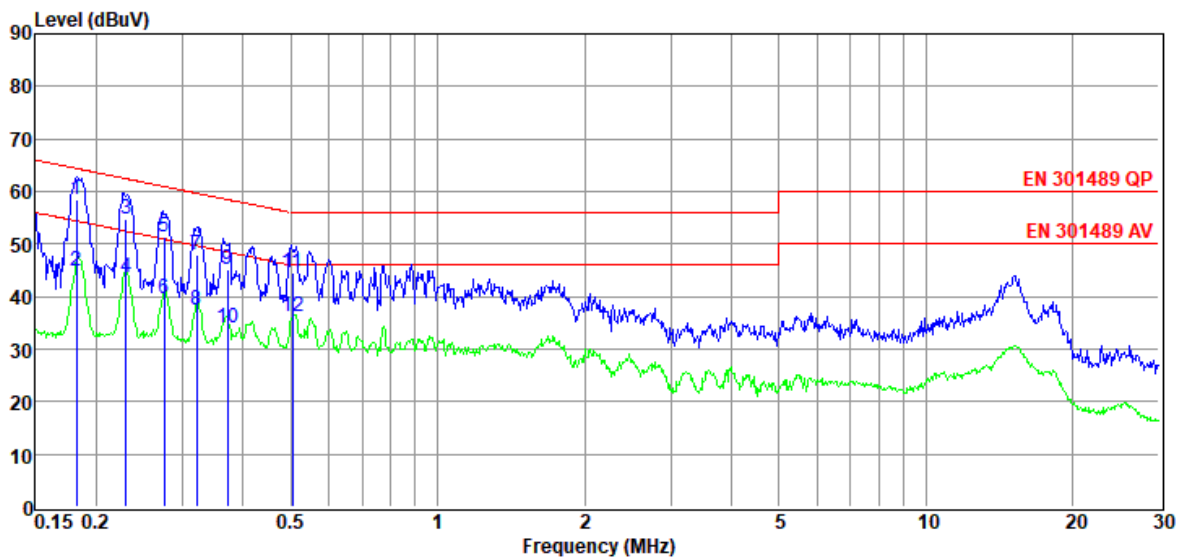

Item (Mark)	Freq. (MHz)	Read Level (dBμV)	LISN Factor (dB)	Cable Loss (dB)	Pulse Limiter Factor (dB)	Result Level (dBμV)	Limit Line (dBμV)	Over Limit (dB)	Detector	Phase
1	0.18	38.77	9.66	0.18	9.78	58.39	64.37	-5.98	QP	NEUTRAL
2	0.18	25.12	9.66	0.18	9.78	44.74	54.37	-9.63	Average	NEUTRAL
3	0.23	35.24	9.66	0.18	9.78	54.86	62.44	-7.58	QP	NEUTRAL
4	0.23	23.85	9.66	0.18	9.78	43.47	52.44	-8.97	Average	NEUTRAL
5	0.28	31.60	9.65	0.19	9.78	51.22	60.94	-9.72	QP	NEUTRAL
6	0.28	19.95	9.65	0.19	9.78	39.57	50.94	-11.37	Average	NEUTRAL
7	0.32	28.35	9.65	0.19	9.78	47.97	59.66	-11.69	QP	NEUTRAL
8	0.32	17.66	9.65	0.19	9.78	37.28	49.66	-12.38	Average	NEUTRAL
9	0.37	25.56	9.65	0.19	9.78	45.18	58.47	-13.29	QP	NEUTRAL
10	0.37	14.33	9.65	0.19	9.78	33.95	48.47	-14.52	Average	NEUTRAL
11	0.50	24.80	9.64	0.20	9.78	44.42	56.00	-11.58	QP	NEUTRAL
12	0.50	16.43	9.64	0.20	9.78	36.05	46.00	-9.95	Average	NEUTRAL

- Note: 1. Result Level = Read Level + LISN Factor + Pulse Limiter Factor + Cable loss.
 2. If QP Result complies with AV limit, AV Result is deemed to comply with AV limit.
 3. Test setup: RBW: 200 Hz (9 kHz—150 kHz), 9 kHz (150 kHz—30 MHz).
 4. Step size: 80Hz (0.009MHz-0.15MHz), 4 kHz (0.15MHz-30MHz), Scan time: auto.

3.8. Test photo



4. Radiated emissions test

4.1. General information

Project No.	: DDT-R19080620-1E1
Test and report Engineer	: Telamon
Test and report Date	: Aug. 29, 2019

4.2. Test Equipment

Equipment	Manufacturer	Model No.	Serial No.	Last Cal.	Cal. Interval
Radiation 2#chamber (below 1G)					
Test Receiver	R&S	ESCI	101028	Sep. 21, 2018	1 Year
Trilog Broadband Antenna	Schwarzbeck	VULB 9163	9163-994	Nov. 16, 2018	1 Year
RF Cable	MI Cable	N/A	DDT-F02-23 3	Oct. 12, 2018	1 Year
RF Cable	MI Cable	N/A	DDT-F02-23 4	Oct. 12, 2018	1 Year
RF Cable	MI Cable	N/A	DDT-F02-23 5	Oct. 12, 2018	1 Year
Test software	Audix	E3	V 6.11111b	N/A	N/A
Radiation 1#chamber (above 1G)					
EMI Test Receiver	R&S	ESU8	100316	Oct. 12, 2018	1 Year
Spectrum analyzer	Agilent	E4447A	MY5018003 1	Oct. 12, 2018	1 Year
Double Ridged Horn Antenna	R&S	HF907	100276	Oct. 12, 2018	1 Year
Pre-amplifier	TERA-MW	TRLA-0040G35	101303	Oct. 12, 2018	1 Year
Pre-amplifier	A.H.	PAM-0118	360	Oct. 12, 2018	1 Year
RF Cable	N/A	SMAJ-SMAJ-1M + SMAJ-SMAJ-11 M	17070133+1 7070131	Oct. 12, 2018	1 Year
Test software	Audix	E3	V 6.11111b	N/A	N/A

4.3. Reference Standard

Draft EN 301 489-1 V2.2.1: 2019-03; Final draft EN 301 489-3 V2.1.1 (2017-03);

4.4. Block diagram of test setup

Below 1GHz

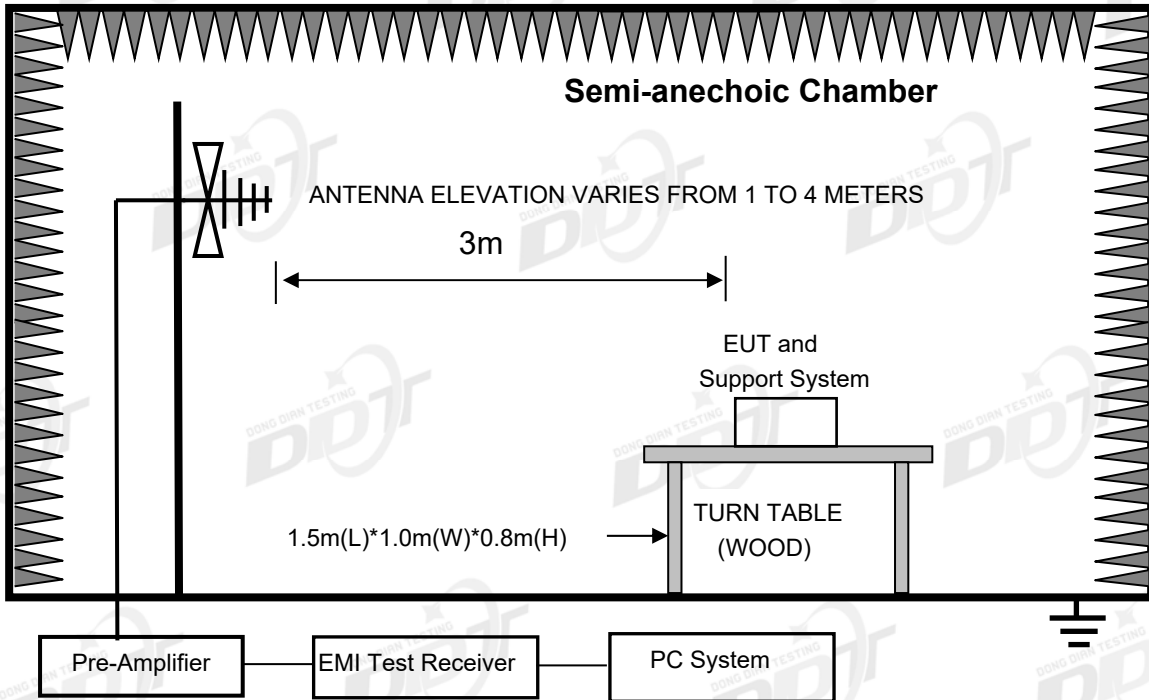

Above 1GHz

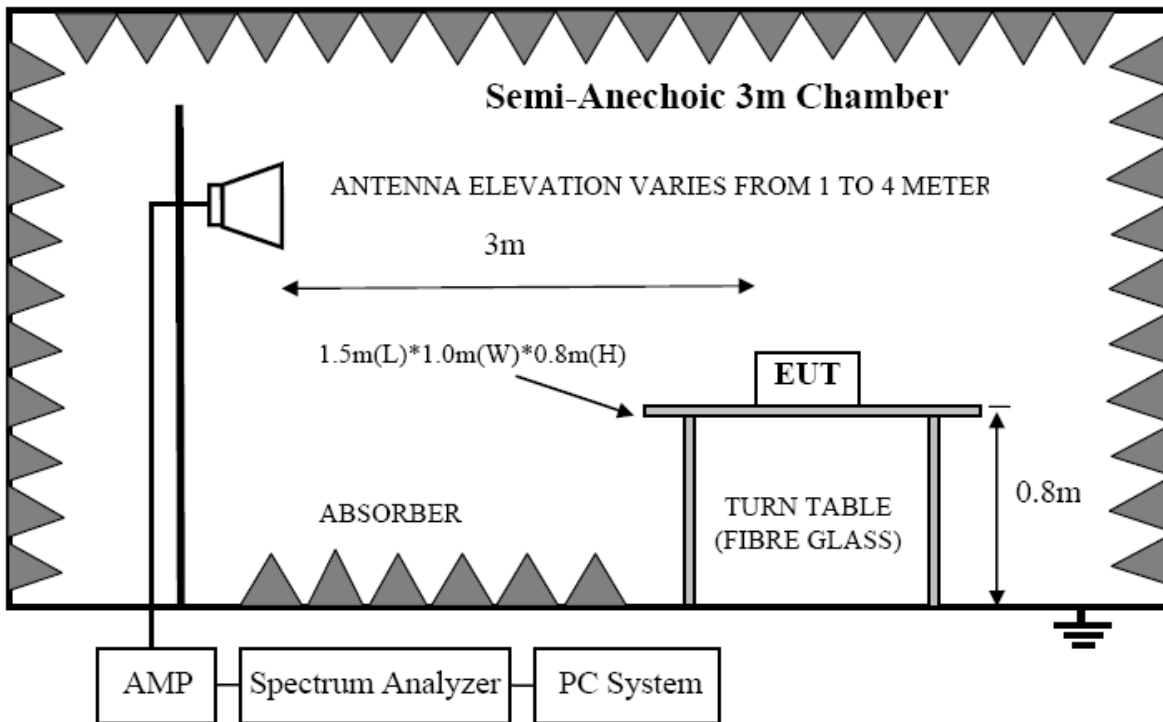

4.5. Radiated disturbance limit of class B

Frequency	Field Strengths Limits at 10m measuring distance dB(μ V)/m	Field Strengths Limits at 3m measuring distance dB(μ V)/m
30MHz to 230MHz	30	40
230MHz to 1000MHz	37	47
1GHz to 3GHz	/	Average:50; Peak:70
3GHz to 6GHz	/	Average:54; Peak:74

Note: (1) The smaller limit shall apply at the cross point between two frequency bands.

(2) Distance is the distance in meters between the measuring instrument, antenna and the closest point of any part of the device or system.

(3) According EN 301489, if the field-strength measurement at 10 m cannot be made because of high ambient noise levels, or for other reasons, measurement of class B EUT's may be made at a closer distance, for example 3 m. An inverse proportionality factor of 20 dB per decade should be used to normalize the measured data to specified distance for determining compliance.

4.6. Test Procedure

- (1) The EUT was placed on a non-metallic table, 80 cm above the ground plane inside an semi-anechoic chamber.
- (2) Test antenna was located 3m (see note) from the EUT on an adjustable mast. A pre-scan was first performed in order to find prominent radiated emissions. For final emissions measurements at each frequency of interest, the EUT were rotated and the antenna height was varied between 1m and 4m in order to maximize the emission. Measurements in both horizontal and vertical polarities were made and the data was recorded. In order to find the maximum emission, the relative positions of equipments and all of the interface cables were changed according to EN 301489 on radiated emission test.
- (3) Spectrum frequency from 30MHz to 1GHz 6GHz was investigated.
- (4) For final emissions measurements at each frequency of interest, the EUT were rotated and the antenna height was varied between 1m and 4m in order to maximize the emission. Measurements in both horizontal and vertical polarities were made and the data was recorded. In order to find the maximum emission, the relative positions of equipments and all of the interface cables were changed according to EN301489 on Radiated Emission test.
- (5) For emissions from 30MHz to 1GHz, Quasi-Peak values were measured with EMI Receiver and the bandwidth of Receiver is 120 kHz.
- (6) For emissions above 1GHz, both Peak and Average level were measured with Spectrum Analyzer, and the RBW is set at 1MHz VBW is set at 3MHz.

4.7. Test result

PASS. (See below detailed test result)

Radiated Emission test (below 1GHz) TR-4-E-009 Radiated Emission Test Result

Test Site : DDT 3m Chamber 2# **E:**2019 RE2# Test Data\B\BOSHENG\20190829 RE.EM6
Test Date : 2019-08-29 **Tested By** : Telamon
EUT : Wireless Extender **Model Number** : PET100W
Power Supply : AC 230V/50Hz **Test Mode** : Tx+ Rx mode
Condition : Temp:24.5°C,Humi:55%,Press:101.4kPa **Antenna/Distance** : 2018 VULB 9163 2#/3m/VERTICAL
Memo :

Data: 2

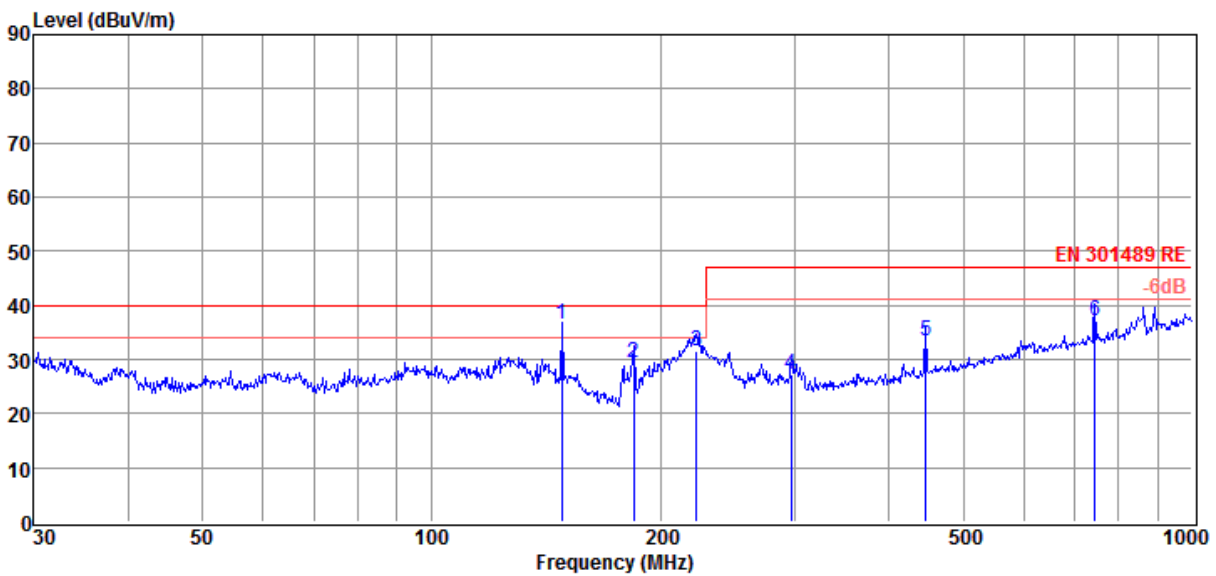

Item (Mark)	Freq. (MHz)	Read Level (dBμV)	Antenna Factor (dB/m)	Cable Loss (dB)	Result Level (dBμV/m)	Limit Line (dBμV/m)	Over Limit (dB)	Detector	Polarization
1	148.44	23.70	8.18	4.54	36.42	40.00	-3.58	QP	VERTICAL
2	184.49	14.63	10.13	4.77	29.53	40.00	-10.47	QP	VERTICAL
3	222.95	14.64	11.95	4.96	31.55	40.00	-8.45	QP	VERTICAL
4	297.22	7.82	13.94	5.35	27.11	47.00	-19.89	QP	VERTICAL
5	446.41	11.05	16.19	6.07	33.31	47.00	-13.69	QP	VERTICAL
6	744.87	9.43	20.17	7.50	37.10	47.00	-9.90	QP	VERTICAL

Note: 1. Result Level = Read Level + Antenna Factor + Cable loss.
 2. If Peak Result complies with QP limit, QP Result is deemed to comply with QP limit.
 3. Test setup: RBW: 120 kHz, VBW: 300 kHz, Sweep time: auto.

TR-4-E-009 Radiated Emission Test Result

Test Site : DDT 3m Chamber 2# E:\2019 RE2# Test Data\B\BOSHENG\20190829 RE.EM6
Test Date : 2019-08-29 **Tested By** : Telamon
EUT : Wireless Extender **Model Number** : PET100W
Power Supply : AC 230V/50Hz **Test Mode** : Tx+ Rx mode
Condition : Temp:24.5°C,Humi:55%,Press:101.4kPa **Antenna/Distance** : 2018 VULB 9163 2#/3m/HORIZONTAL
Memo :

Data: 3

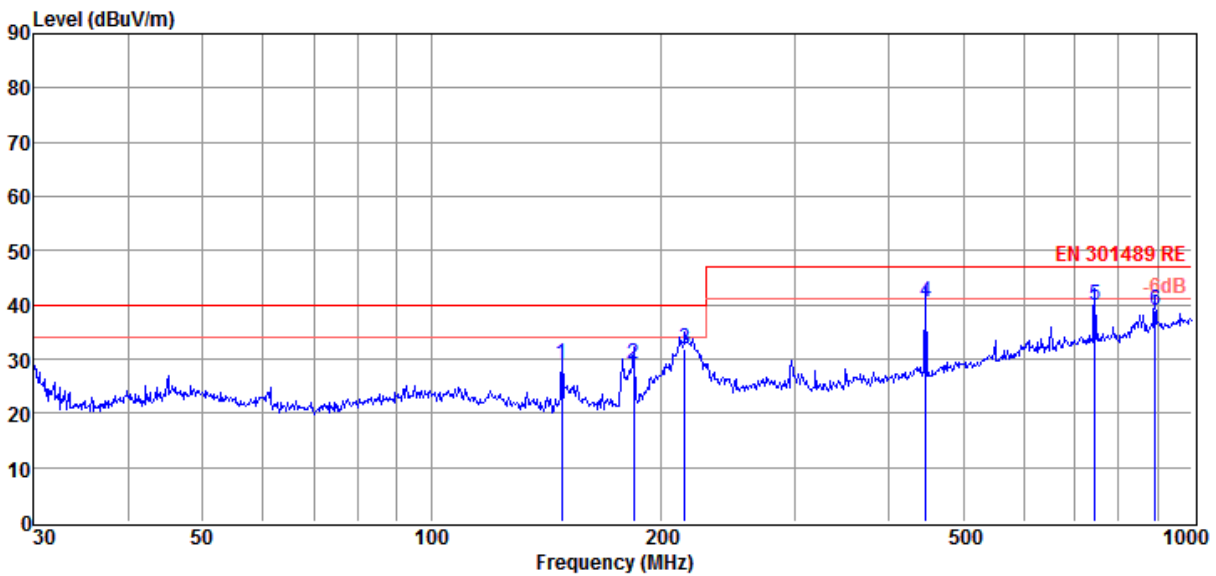

Item (Mark)	Freq. (MHz)	Read Level (dBμV)	Antenna Factor (dB/m)	Cable Loss (dB)	Result Level (dBμV/m)	Limit Line (dBμV/m)	Over Limit (dB)	Detector	Polarization
1	148.44	16.41	8.18	4.54	29.13	40.00	-10.87	QP	HORIZONTAL
2	184.49	14.21	10.13	4.77	29.11	40.00	-10.89	QP	HORIZONTAL
3	215.27	15.27	11.71	4.92	31.90	40.00	-8.10	QP	HORIZONTAL
4	446.41	18.39	16.19	6.07	40.65	47.00	-6.35	QP	HORIZONTAL
5	744.87	12.18	20.17	7.50	39.85	47.00	-7.15	QP	HORIZONTAL
6	893.86	8.90	21.92	8.05	38.87	47.00	-8.13	QP	HORIZONTAL

Note: 1. Result Level = Read Level + Antenna Factor + Cable loss.
 2. If Peak Result complies with QP limit, QP Result is deemed to comply with QP limit.
 3. Test setup: RBW: 120 kHz, VBW: 300 kHz, Sweep time: auto.

Radiated Emission test (Above 1 GHz)

Freq. (MHz)	Read level (dBµV)	Antenna Factor (dB/m)	PRM Factor (dB)	Cable Loss (dB)	Result Level (dBµV/m)	Limit (dBµV/m)	Margin (dB)	Detector type	Polarization
Power Supply: AC 230V/50Hz			Test mode: Mode 1			Memo:			
1633.86	55.85	26.19	43.88	2.81	40.97	70.00	-29.03	Peak	VERTICAL
1937.04	56.37	27.97	43.98	3.08	43.44	70.00	-26.56	Peak	VERTICAL
2227.58	56.51	28.78	44.11	3.48	44.66	70.00	-25.34	Peak	VERTICAL
2816.90	55.57	30.54	44.34	4.13	45.90	70.00	-24.10	Peak	VERTICAL
3418.31	56.25	31.96	44.40	4.69	48.50	74.00	-25.50	Peak	VERTICAL
5757.76	37.31	34.51	44.05	6.36	34.13	54.00	-19.87	Average	VERTICAL
1559.49	56.33	25.71	43.86	2.74	40.92	70.00	-29.08	Peak	HORIZONTAL
1933.57	55.75	27.95	43.98	3.08	42.80	70.00	-27.20	Peak	HORIZONTAL
2219.61	56.31	28.77	44.10	3.47	44.45	70.00	-25.55	Peak	HORIZONTAL
2427.64	61.13	29.17	44.19	3.78	49.89	70.00	-20.11	Peak	HORIZONTAL
3549.38	56.01	32.18	44.40	4.82	48.61	74.00	-25.39	Peak	HORIZONTAL
4377.20	55.39	33.44	44.32	5.39	49.90	74.00	-24.10	Peak	HORIZONTAL
Result: Pass									

Note: Result Level = Read Level + Antenna Factor + Cable loss - PRM Factor.

4.8. Test photo

Radiated Emission test Photo (80MHz-1GHz)





5. Harmonic current and Voltage fluctuations & flicker test report

5.1. General information

Project No.	: DDT-R19080620-1E1
Test and report Engineer	: Eddie
Test and report Date	: Sep. 05, 2019

5.2. Test Equipment

Equipment	Manufacturer	Model No.	Serial No.	Last Cal.	Cal. Interval
HARMONICS and Voltage fluctuation and flicker tester	EMC-PARTNER	HAR1000-1P	HAP1000-1P230 V-0205	Jun. 18, 2019	1 Year
Test Software	EMC-PARTNER	Harmonics-1000	4.19	N/A	N/A

5.3. Test Standard

EN 61000-3-2:2014, Classification of equipment: Class A, Class B, Class C, Class D.

EN 61000-3-3:2013

5.4. Block diagram of test setup

(1) Table-top device

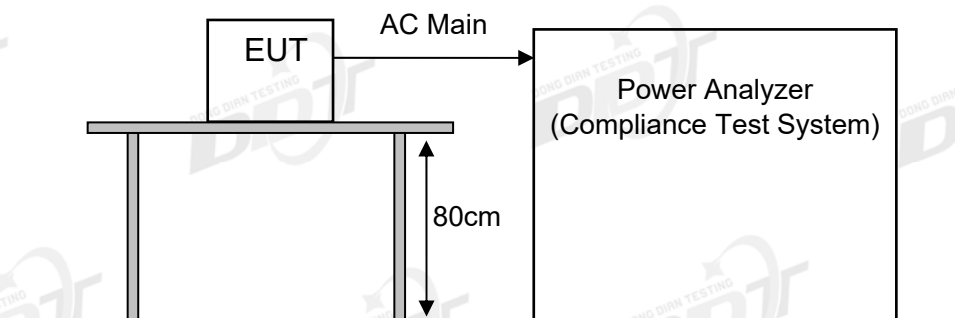

5.5. Harmonic current limits

For Class A equipment

Harmonic order(n)	Maximum permissible harmonic current (A)
3	2.30
5	1.14
7	0.77
9	0.40
11	0.33
13	0.21
$15 \leq n \leq 39$	$0.15 * 15/n$
Even harmonics	
2	1.08
4	0.43
6	0.30
$8 \leq n \leq 40$	$0.23 * 8/n$

For Class B equipment

The harmonics of the input current shall not exceed the values given in class A equipment limits multiplied by a factor of 1.5.

For Class C equipment

Harmonic order(n)	Maximum permissible harmonic current expressed as a percentage of the input current at the fundamental frequency %
2	2
3	$30 \times \lambda$
5	10
7	7
9	3
$11 \leq n \leq 39$ (odd harmonic only)	$0.23 * 8/n$

Note: λ is the circuit power factor.

For Class D equipment

Harmonic order(n)	Maximum permissible harmonic current per watt mA/W	Maximum permissible harmonic current (A)
3	3.4	2.30
5	1.9	1.14
7	1.0	0.77
9	0.5	0.40
11	0.35	0.33
$13 \leq n \leq 39$ (odd harmonic only)	$3.85/n$	Refer to Class A limit

5.6. Voltage fluctuations & flicker Limit

Test Item	Limit	Note
Pst	1.0	Pst means Short-term flicker indicator
Plt	0.65	Plt means long-term flicker indicator
Tdt	0.2	Tdt means maximum time that dt exceeds 3%
dmax(%)	4%	dmax means maximum relative voltage change.
dc(%)	3%	dc means relative steady-state voltage change.

5.7. Test Procedure

For Harmonic current test:

The EUT was placed on the top of a wooden table 0.8 meters above the ground and operated to produce the maximum harmonic components under normal operating conditions for each successive harmonic component in turn. The correspondent test program of test instrument to measure the current harmonics emanated from EUT is chosen. The measure time shall be not less than the necessary for the EUT to be exercised.

For Voltage fluctuations & flicker

The EUT was placed on the top of a wooden table 0.8 meters above the ground and operated to produce the most unfavorable sequence of voltage changes under normal conditions during the flick measurement; the measure time shall include that part of whole operation changes. The observation period for short-term flicker indicator is 10 minutes and the observation period for long-term flicker indicator is 2 hours.

5.8. Test result

Harmonic current test result:

Not Applicable

This product is not defined as lighting equipment, and has rated power less than 75W, therefore, no limit apply according to EN 61000-3-2 harmonics currents emissions test.

Voltage fluctuations & flicker test result:

Tx:

Flicker Emission IEC 61000-4-15 for 230V/50Hz

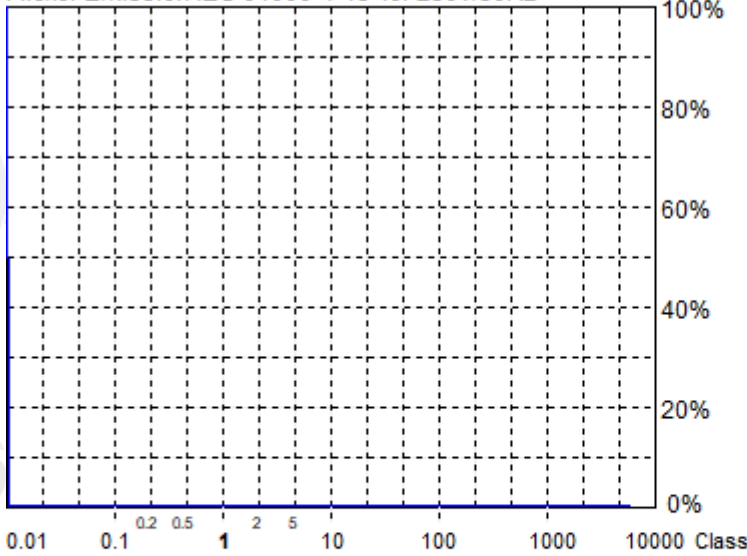

Actual Flicker (Fli):	0.00
Short-term Flicker (Pst):	0.07
Limit (Pst):	1.00
Long-term Flicker (Plt):	0.07
Limit (Plt):	0.65
Maximum Relative Volt. Change (dmax):	0.00%
Limit (dmax):	4.00%
Relative Steady-state Voltage Change (dc):	0.01%
Limit (dc):	3.00%
Tmax 3.00% (dt):	0.00ms
Limit (dt>Lim):	200ms

Flicker Emission - IEC 61000-3-3 , EN 61000-3-3

2019/9/5 18:31:48

Urms = 231.5 V P = 4.749 W
 Irms = 0.051 A pf = 0.402

Range: 0.5 A
 V-nom: 230 V
 TestTime: 10 min (100%)

Test completed, Result: PASSED

HAR-1000 EMC-Partner

Full Bar : Actual Values
 Empty Bar : Maximum Values
 Circles : Average Values
 Blue : Current , Green : Voltage , Red : Failed

Measurement

Urms = 231.5V Freq = 50.000 Range: 0.5 A
 Irms = 0.051A Ipk = 0.283A cf = 5.545
 P = 4.749W S = 11.81VA pf = 0.402

Test - Time : 1 x 10min = 10min (100 %)

LIN (Line Impedance Network) : L: 0.24ohm +j0.15ohm N: 0.16ohm +j0.10ohm

Limits : Plt : 0.65 Pst : 1.00
 dmax : 4.00 % dc : 3.00 %
 dtLim: 3.00 % dt>Lim: 200ms

Test completed, Result: PASSED

dmax [%]
 1 0.000

Tx:
Rx:

Flicker Emission IEC 61000-4-15 for 230V/50Hz

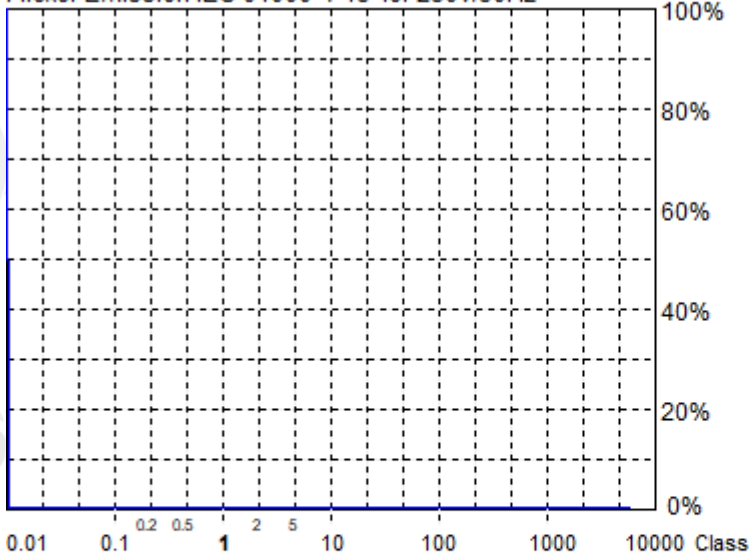

Actual Flicker (Fli): 0.00
Short-term Flicker (Pst): 0.07
 Limit (Pst): 1.00
Long-term Flicker (Plt): 0.07
 Limit (Plt): 0.65
Maximum Relative Volt. Change (dmax): 0.00%
 Limit (dmax): 4.00%
Relative Steady-state Voltage Change (dc): 0.01%
 Limit (dc): 3.00%
Tmax 3.00% (dt): 0.00ms
 Limit (dt>Lim): 200ms

Flicker Emission - IEC 61000-3-3 , EN 61000-3-3

Urms = 231.7 V P = 4.896 W
 Irms = 0.052 A pf = 0.403

2019/9/5 18:44:24

Range: 0.5 A
 V-nom: 230 V
 TestTime: 10 min (100%)

Test completed, Result: PASSED

HAR-1000 EMC-Partner

Full Bar : Actual Values
 Empty Bar : Maximum Values
 Circles : Average Values
 Blue : Current , Green : Voltage , Red : Failed

Measurement

Urms = 231.7V Freq = 50.000 Range: 0.5 A
 Irms = 0.052A Ipk = 0.287A cf = 5.465
 P = 4.896W S = 12.16VA pf = 0.403

Test - Time : 1 x 10min = 10min (100 %)

LIN (Line Impedance Network) : L: 0.24ohm +j0.15ohm N: 0.16ohm +j0.10ohm

Limits : Plt : 0.65 Pst : 1.00
 dmax : 4.00 % dc : 3.00 %
 dtLim: 3.00 % dt>Lim: 200ms

Test completed, Result: PASSED

1 dmax [%] 0.000

5.9. Test photo



6. Electrostatic discharge test report

6.1. General information

Project No.	: DDT-R19080620-1E1
Test and report Engineer	: Eddie
Test and report Date	: Sep. 05, 2019

6.2. Test Equipment

Equipment	Manufacturer	Model No.	Serial No.	Last Cal.	Cal. Interval
ESD Generator	TESEQ	NSG 437	981	Nov. 05, 2018	1 Year

6.3. Test and Reference Standards

Draft EN 301 489-1 V2.2.1: 2019-03; Final draft EN 301 489-3 V2.1.1 (2017-03);

6.4. Block diagram of test setup

(1) Table-top equipment

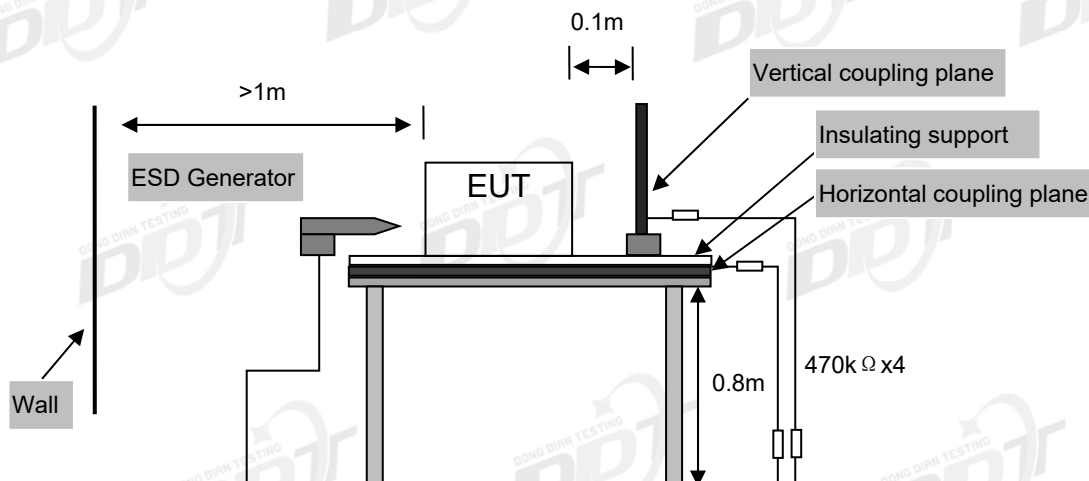

6.5. Test levels and performance criterion

Test Level		Performance Criteria
Air Discharge	±2kV, ±4kV and ±8kV	B
Contact Discharge	±4kV	

Performance criteria B description: During the test, degradation of performance is allowed. However, no change of operating state or stored data is allowed to persist after the test. After the test, the EUT shall continue to operate as intended without operator intervention. No degradation of performance or loss of function is allowed, after the application of the phenomena below a performance level specified by the manufacturer, when the EUT is used as intended.

6.6. Test Procedure

Air Discharge:

The test was applied on non-conductive surfaces of EUT. The round discharge tip of the discharge electrode was approached as fast as possible to touch the EUT. After each discharge, the discharge electrode was removed from the EUT. The generator was re-triggered for a new single discharge and repeated 20 times for each pre-selected test point. This procedure was repeated until all the air discharge completed.

Contact Discharge:

All the procedure was same as air discharge. Except that the generator was re-triggered for a new single discharge and repeated 20 times for each pre-selected test point. The tip of the discharge electrode was touching the EUT before the discharge switch was operated.

Indirect discharge for horizontal coupling plane:

At least 20 single discharges were applied to the horizontal coupling plane, at points on each side of the EUT. The discharge electrode positions vertically at a distance of 0.1m from the EUT and with the discharge electrode touching the coupling plane.

Indirect discharge for vertical coupling plane:

At least 20 single discharges were applied to the center of one vertical edge of the coupling plane. The coupling plane, of dimensions 0.5m X 0.5m, was placed parallel to, and positioned at a distance of 0.1m from the EUT. Discharges were applied to the coupling plane, with this plane in sufficient different positions that the four faces of the EUT are completely illuminated.

6.7. Test result

Ambient Condition : <u>23.4 °C</u> <u>50.5 %RH</u> <u>101.4 kPa</u>						
Test Power supply: <u>AC 230V/50Hz</u> Test Site: DDT 3# Shield Room						
Test Times: 20 times at each point for contact discharge; 20 times at each point for air discharge.						
Operation Mode	Type of discharge	Test Level	Test Point	Performance		Result (Pass/Fail)
				Required	Observation	
Mode 1	Contact to EUT	±4kV	1	B	A	Pass
	Contact to Coupling Planes	±4kV	Coupling Planes	B	A	Pass
	Air	±2kV, ±4kV, and ±8kV	1, 2	B	A	Pass
Test Point:						
No.	Description	No.	Description	No.	Description	
1	Shell					
2	DC input port					
Observation Description: A: Operation as intend, no loss of function during test and after test.						

6.8. Test photo



7. Continuous radio frequency disturbances

7.1. General information

Project No.	: DDT-R19080620-1E1
Test and report Engineer	: Eddie
Test and report Date	: Sep. 05, 2019

7.2. Test Equipment

Equipment	Manufacturer	Model No.	Serial No.	Last Cal.	Cal. Interval
RF Strength Susceptibility Test					
Signal Generator	Agilent	N5172B	MY53050018	Oct. 12, 2018	1 Year
Amplifier	Wonder	HPA80M1000M500	101	Oct. 12, 2018	1 Year
Amplifier	Wonder	HPA1000M2500M300	102	Oct. 12, 2018	1 Year
Amplifier	Wonder	HPA2500M6000M200	103	Oct. 12, 2018	1 Year
Power meter	Agilent	N1912A	MY50000460	Oct. 12, 2018	1 Year
Power sensor	Agilent	E9323	MY44420907	Oct. 12, 2018	1 Year
Power sensor	Agilent	E9323	US40410405	Oct. 12, 2018	1 Year
Log-periodic antenna	Schwarzbeck	STLP 9149	587	Oct. 17, 2018	1 Year
Log-periodic antenna	Schwarzbeck	STLP 9128D special	090	Oct. 17, 2018	1 Year
Field strength probe	PMM	EP-601	611WX80209	Nov. 17, 2018	1 Year

7.3. Test and Reference Standards

Draft EN 301 489-1 V2.2.1: 2019-03; Final draft EN 301 489-3 V2.1.1 (2017-03);

7.4. Block diagram of test setup

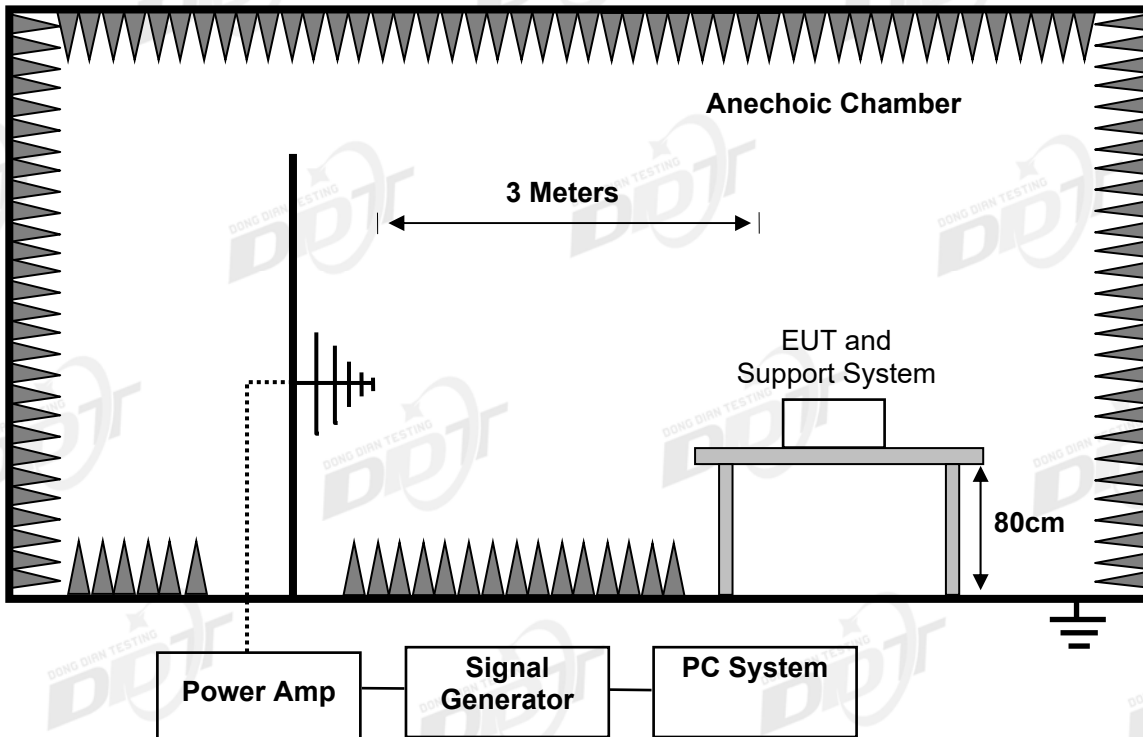

7.5. Test levels and performance criterion

Test Level		Performance Criteria
Frequency	80MHz-6GHz	A
Field Strength	3V/m measured unmodulated	
Modulation	AM modulated to a depth of 80% by a sinusoidal audio signal of 1KHz	
Step Size	10% increments	
Dwell time	1 Sec.	

7.6. Test Procedure

The test procedure was in accordance with EN 61000-4-3

The testing was performed in a fully anechoic chamber. The transmit antenna was located at a distance of 3 meters from the EUT.

The frequency range is swept from 80 MHz to 6GHz, with the signal 80% amplitude modulated with a 400 Hz sine-wave. The rate of sweep did not exceed 1.5×10^{-3} decade/s, where the frequency range is swept incrementally; the step size was 1% of preceding frequency value.

The dwell time at each frequency shall be not less than the time necessary for the EUT to be able to respond.

The test was performed with the EUT exposed to both vertically and horizontally polarized fields on each of the four sides.

The frequency on which the transmitter part of the EUT is intended to operate shall be excluded from conducted and radiated emission measurements when performed in transmit mode of operation.

7.7. Test result

Ambient Condition : <u>23.4</u> °C <u>50.5</u> %RH <u>101.4</u> kPa						
Test Power supply: <u>AC 230V/50Hz</u>						
Field Strength: <input checked="" type="checkbox"/> 3V/m <input type="checkbox"/> 10V/m <input type="checkbox"/> Other: Steps: <input checked="" type="checkbox"/> 1% Dwell time: <input checked="" type="checkbox"/> 1s <input type="checkbox"/> other:						
Swept Frequency Range: <input checked="" type="checkbox"/> 80MHz---6GHz; <input type="checkbox"/> other:						
Modulation: <input type="checkbox"/> None <input checked="" type="checkbox"/> AM <input type="checkbox"/> 1KHz <input checked="" type="checkbox"/> 400Hz Modulation depth: <input checked="" type="checkbox"/> 80% <input type="checkbox"/> other:						
Operation Mode	EUT Position towards antenna	Antenna: Horizontal		Antenna: Vertical		Result (Pass/Fail)
		Required	Observation	Required	Observation	
Mode 1	Front	A	A	A	A	Pass
	Right	A	A	A	A	Pass
	Rear	A	A	A	A	Pass
	Left	A	A	A	A	Pass
Observation Description: A: Operation as intend, no loss of function during test and after test.						

7.8. Test photo

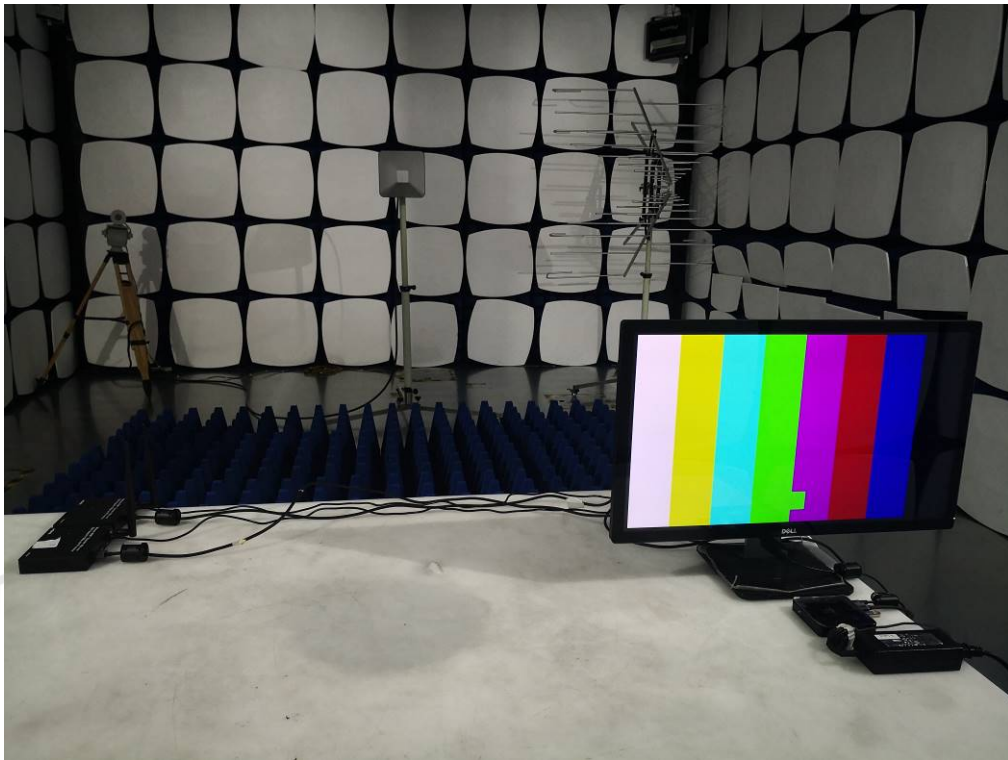
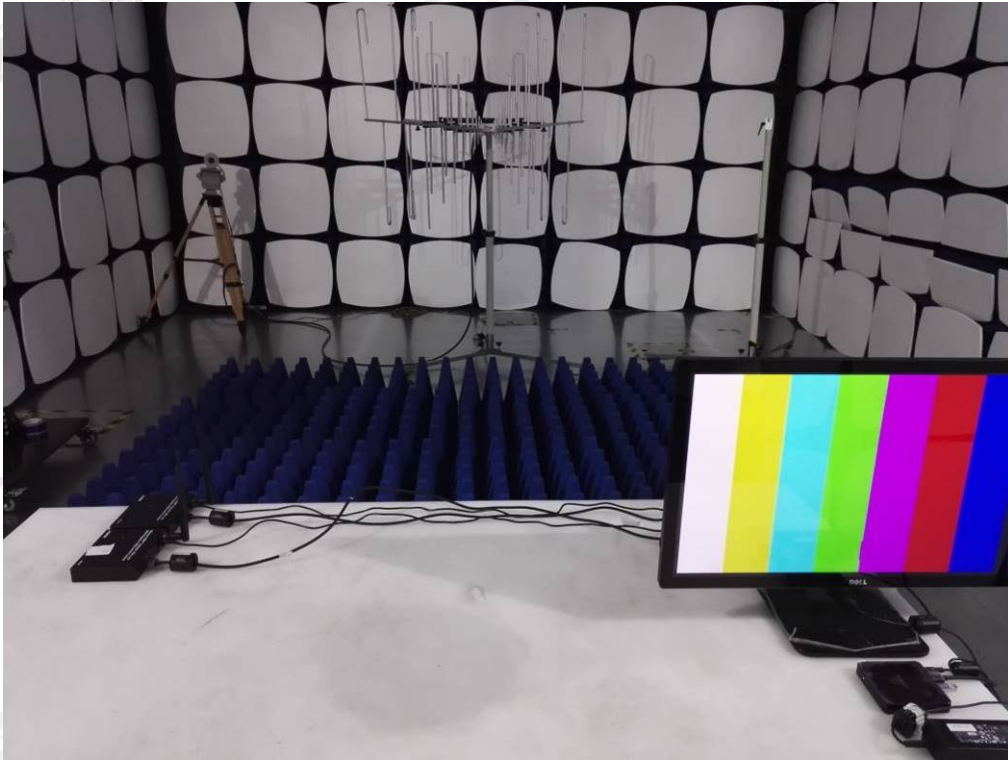

8. Electrical fast transients (EFT) test report

8.1. General information

Project No.	: DDT-R19080620-1E1
Test and report Engineer	: Eddie
Test and report Date	: Sep. 05, 2019

8.2. Test Equipment

Equipment	Manufacturer	Model No.	Serial No.	Last Cal.	Cal. Interval
EFT Generator	EMC PARTNER	TRA3000F	TRA3000F-1502	Jun. 25, 2019	1 Year
Capacitive coupling clamp	EMC PARTNER	103648	CN-EFT1000-1514	Jun. 25, 2019	1 Year

8.3. Test and Reference Standards

Draft EN 301 489-1 V2.2.1: 2019-03; Final draft EN 301 489-3 V2.1.1 (2017-03);

8.4. Block diagram of test setup

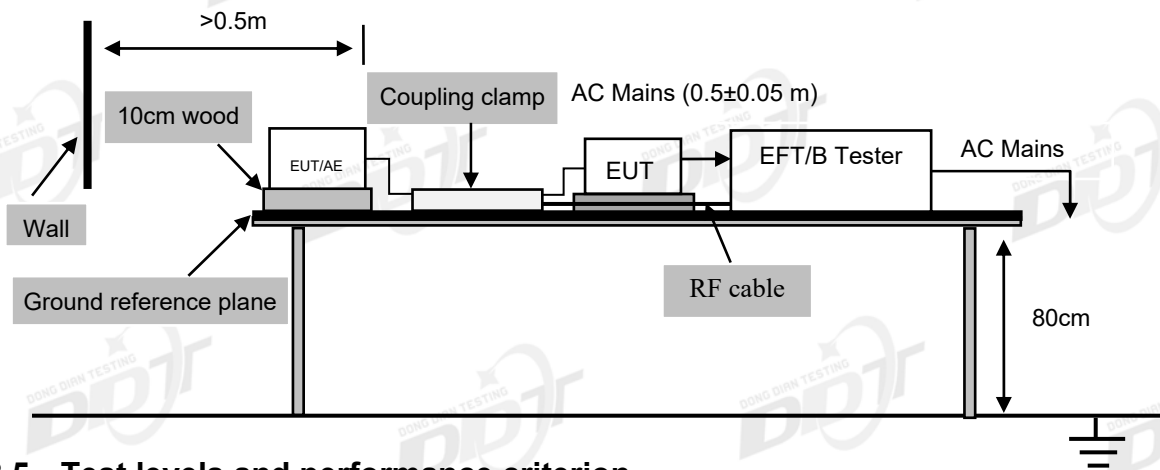
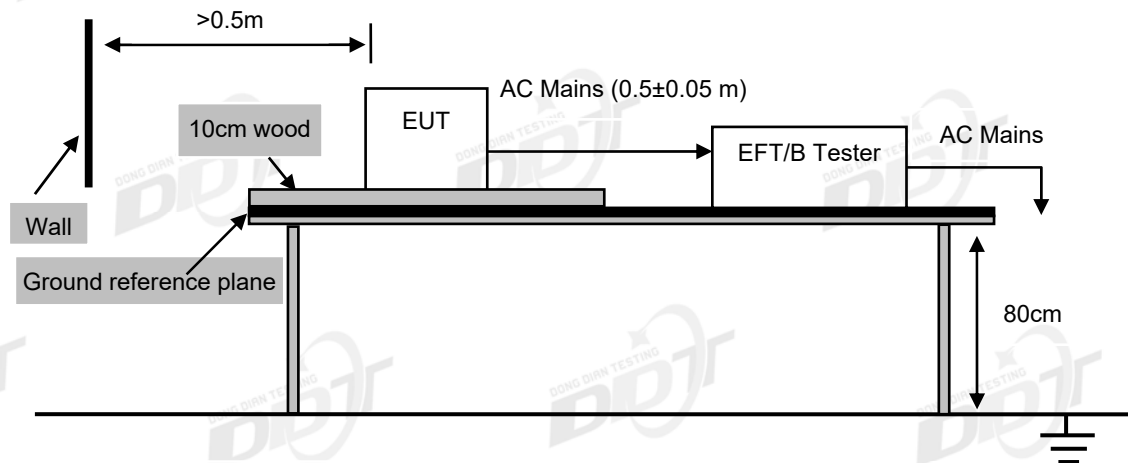

8.5. Test levels and performance criterion

Test Level		Performance Criteria
Test voltage	±1KV For AC mains Port	B
Repetition Frequency	5KHz	
Burst Duration	15ms	
Burst Period	300ms	
Inject Time(s)	120s	
Inject Method	Direct For AC mains port	
Inject Line	AC Mains of adapter	

Performance criteria B description: During the test, degradation of performance is allowed. However, no change of operating state or stored data is allowed to persist after the test. After the test, the EUT shall continue to operate as intended without operator intervention. No degradation of performance or loss of function is allowed, after the application of the phenomena below a performance level specified by the manufacturer, when the EUT is used as intended.

8.6. Test Procedure

The EUT and its simulators were placed on the ground reference plane and were insulated from it by a wood support 0.1m + 0.01m thick. The ground reference plane was 1m*1m metallic sheet with 0.65mm minimum thickness. This reference ground plane was project beyond the EUT by at least 0.1m on all sides and the minimum distance between EUT and all other conductive structure, except the ground plane was more than 0.5m. All cables to the EUT was placed on the wood support, cables not subject to EFT/B was routed as far as possible from the cable under test to minimize the coupling between the cables.

For input and AC power ports:

The EUT was connected to the power mains by using a coupling device that couples the EFT interference signal to AC power lines. Both positive transients and negative transients of test voltage were applied during compliance test and the duration of the test can't less than 1min.

8.7. Test result

Ambient Condition : <u>23.4</u> °C <u>50.5</u> %RH <u>101.4</u> kPa						
Test Power supply: <u>AC 230V/50Hz</u> Test Site: DDT 4# Shield Room						
Port: <input checked="" type="checkbox"/> AC Mains <input type="checkbox"/> DC Supply <input type="checkbox"/> Signal : Burst Period: <input checked="" type="checkbox"/> 300ms <input type="checkbox"/> Other:						
Coupling: <input checked="" type="checkbox"/> Direct <input type="checkbox"/> Capacitive Clamp			Test Time: <input checked="" type="checkbox"/> 120S <input type="checkbox"/> Other:			
Repetition Frequency: <input checked="" type="checkbox"/> 5kHz <input type="checkbox"/> 100kHz			Burst Duration: <input checked="" type="checkbox"/> 15ms <input type="checkbox"/> Other:			
Memo:						
Operation Mode	Line/port	Test Voltage	Performance			Result (Pass/Fail)
			Required	Observation(+)	Observation(-)	
Mode 1	L	1kV	B	A	A	Pass
	N	1kV	B	A	A	Pass
	L-N	1kV	B	A	A	Pass
Observation Description: A: Operation as intend, no loss of function during test and after test.						

8.8. Test photo



9. Surges test report

9.1. General information

Project No.	: DDT-R19080620-1E1
Test and report Engineer	: Eddie
Test and report Date	: Sep. 05, 2019

9.2. Test Equipment

Equipment	Manufacturer	Model No.	Serial No.	Last Cal.	Cal. Interval
Surge Generator	EMC PARTNER	TRANSIENT2000	MIG0603IN2 S-T-1504	Jun. 25, 2019	1 Year

9.3. Test and Reference Standards

Draft EN 301 489-1 V2.2.1: 2019-03; Final draft EN 301 489-3 V2.1.1 (2017-03);

9.4. Block diagram of test setup

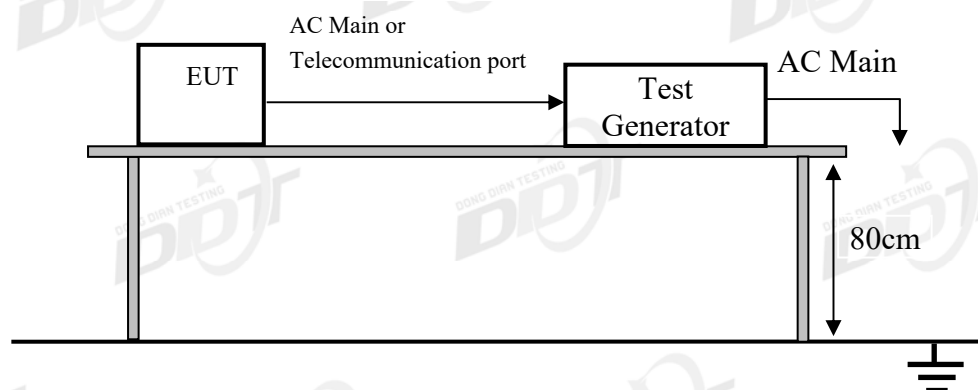

9.5. Test levels and performance criterion

Test level for AC mains ports		Performance Criterion
Line to Line	1KV	B
Line to ground	2KV	B

Performance criteria B description: During the test, degradation of performance is allowed. However, no change of operating state or stored data is allowed to persist after the test. After the test, the EUT shall continue to operate as intended without operator intervention. No degradation of performance or loss of function is allowed, after the application of the phenomena below a performance level specified by the manufacturer, when the EUT is used as intended.

9.6. Test Procedure

For line-to-line coupling mode, provide a 1kV 1.2/50us voltage surge (at pen-circuit condition) and 8/20us current surge to EUT selected points, and for active line / neutral lines to ground are same except test level is 2kV.

At least 5 positive and 5 negative (polarity) tests with a maximum 1/min repetition rate are applied during test.

Different phase angles are done individually.

Record the EUT operating situation during compliance test and decide the EUT immunity criterion for above each test.

9.7. Test result

Ambient Condition : <u>23.4</u> °C <u>50.5</u> %RH <u>101.4</u> kPa											
Test Power supply: <u>AC 230V/50Hz</u>						Test Site: DDT 3# Shield Room					
Line: <input checked="" type="checkbox"/> AC Mains <input type="checkbox"/> DC Supply <input type="checkbox"/> Signal											
Wave Type: <input checked="" type="checkbox"/> 1.2/50us-8/20us <input type="checkbox"/> 10/700 us-5/320us											
Pluse times: 5 times at each polarity				Pulse Interval: 60S				Voltage Phase: 0°, 90°, 180°, 270°			
Memo:											
Operation Mode	Line/Port	0.5kV			1kV			2kV			Result (Pass/Fail)
		Performance			Performance			Performance			
		Required	+	-	Required	+	-	Required	+	-	
Mode 1	L-N	B	A	A	B	A	A	/	/	/	Pass
	L-PE	/	/	/	/	/	/	/	/	/	/
	N-PE	/	/	/	/	/	/	/	/	/	/
Observation Description: A: Operation as intend, no loss of function during test and after test.											

9.8. Test photo



10. Continuous conducted disturbances

10.1. General information

Project No.	: DDT-R19080620-1E1
Test and report Engineer	: Eddie
Test and report Date	: Sep. 05, 2019

10.2. Test Equipment

Equipment	Manufacturer	Model No.	Serial No.	Last Cal.	Cal. Interval
Continuous conducted disturbances					
Conducted immunity test system	FRANKONIA	CIT-10	126B1207	Jun. 25, 2019	1 Year
CDN	FRANKONIA	CDN M2+M3	A2210191	Oct. 12, 2018	1 Year
Attenuation	BIRD	DAM75W (6dB)	1143	Oct. 12, 2018	1 Year
EM Clamp	FRANKONIA	EMCL	132A1143/2012	Oct. 12, 2018	1 Year
CDN	FRANKONIA	CDNT8	A6100017/2012	Oct. 12, 2018	1 Year
Test Software	CD-LAB	F5.318	1435V9992015	N/A	N/A

10.3. Test and Reference Standards

Draft EN 301 489-1 V2.2.1: 2019-03; Final draft EN 301 489-3 V2.1.1 (2017-03);

10.4. Block diagram of test setup

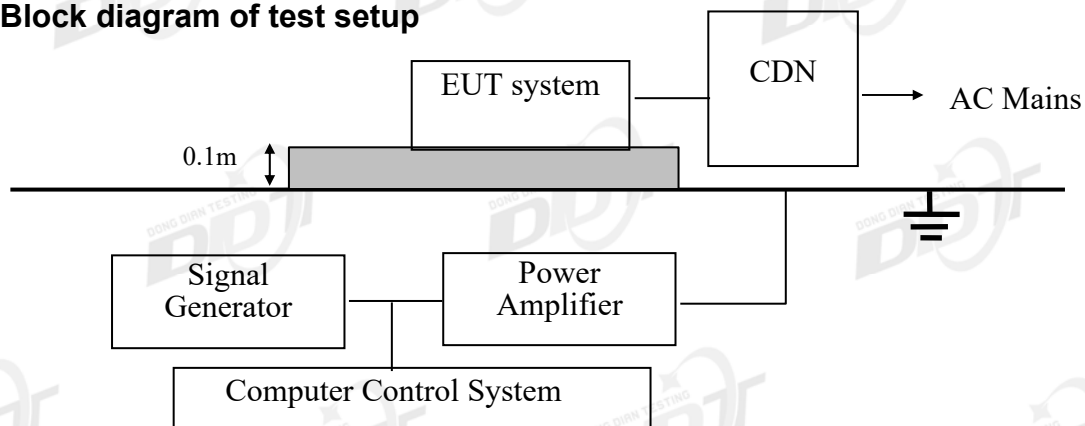

10.5. Test levels and performance criterion

Test Level		Performance Criteria
Frequency	0.15MHz to 80MHz	A
Field Strength	3V measured unmodulated	
Modulation	AM modulated to a depth of 80% by a sinusoidal audio signal of 400Hz	
Step Size	1% or 10% increments	
Dwell time	1 Sec.	

10.6. Test Procedure

The EUT are placed on an insulating support 0.1m high above a ground reference plane. CDN (coupling and decoupling device) is placed on the ground plane about 0.3m from EUT. Cables between CDN and EUT are as short as possible, and their height above the ground reference plane shall be between 30 and 50 mm (where possible).

The disturbance signal described below is injected to EUT through CDN.

The EUT operates within its operational mode(s) under intended climatic conditions after power on.

The frequency range is swept from 0.150MHz to 80MHz using 3V signal level, and with the disturbance signal 80% amplitude modulated with a 400Hz sine wave.

The rate of sweep shall not exceed 1.5×10^{-3} decades/s. Where the frequency is swept incrementally; the step size shall not exceed 1% of the start and thereafter 1% of the preceding frequency value.

Recording the EUT operating situation during compliance testing and decide the EUT immunity criterion.

10.7. Test result

Ambient Condition : <u>23.4 °C</u> <u>50.5 %RH</u> <u>101.4 kPa</u>						
Test Power supply: <u>AC 230V/50Hz</u>				Test Site: DDT 4# Shield Room		
Modulation Signal: <input type="checkbox"/> 1kHz <input checked="" type="checkbox"/> 400Hz 80% AM Steps: <input checked="" type="checkbox"/> 1% Dwell time: <input checked="" type="checkbox"/> 1s <input type="checkbox"/> Other:						
Memo:						
Operation mode	Frequency Range	Injected Position	Strength(e.m.f) (unmodulated)	Required	Observation	Result (Pass/Fail)
Mode 1	0.15MHz-80MHz	AC port	3V	A	A	Pass
Observation Description: A: Operation as intend, no loss of function during test and after test.						

10.8. Test photo

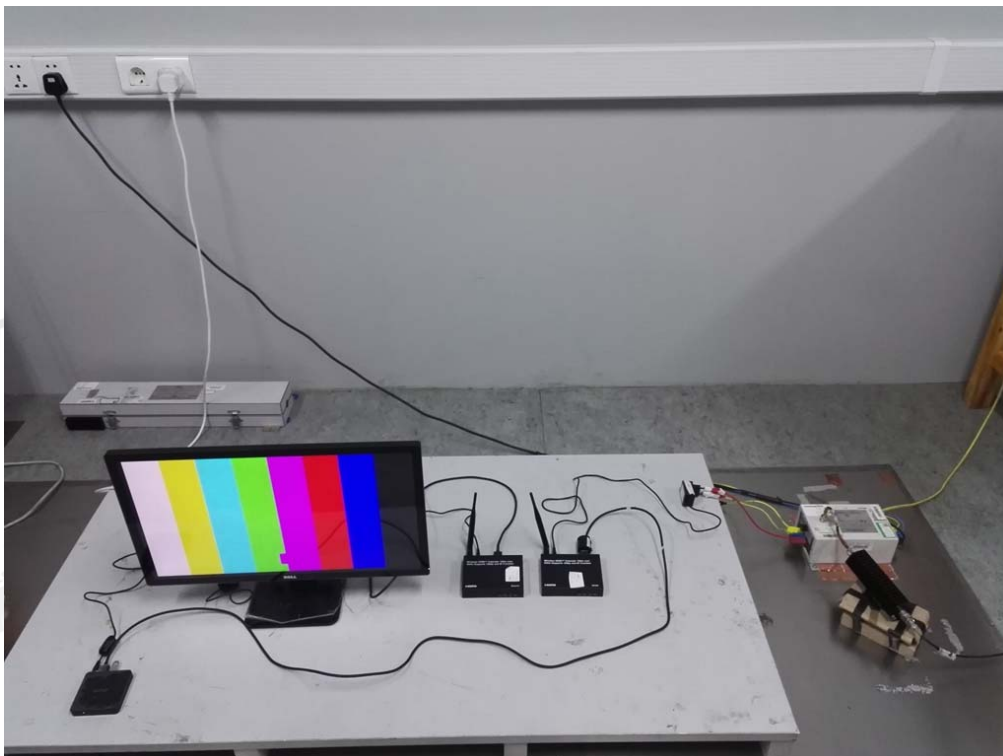

11. Voltage dips and interruptions

11.1. General information

Project No.	: DDT-R19080620-1E1
Test and report Engineer	: Eddie
Test and report Date	: Sep. 05, 2019

11.2. Test Equipment

Equipment	Manufacturer	Model No.	Serial No.	Last Cal.	Cal. Interval
DIPS TESTER	EMC PARTNER	TRA3000D	EXT-TRA3000D-1510	Jun. 25, 2019	1 Year

11.3. Test and Reference Standards

Draft EN 301 489-1 V2.2.1: 2019-03; Final draft EN 301 489-3 V2.1.1 (2017-03);

11.4. Block diagram of test setup

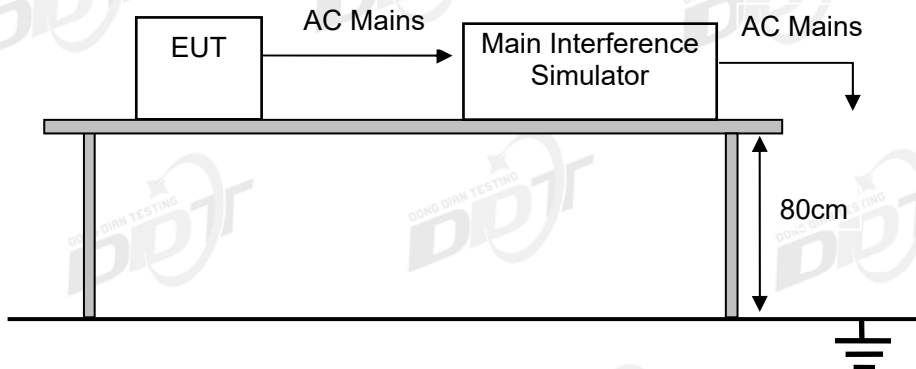

11.5. Test levels and performance criterion

Test Level	Voltage dip and short interruptions		Duration	Performance
%UT	%UT		(in period)	Criterion
0	100		0.5	B
0	100		1	B
70	30		25	B
0	100		250	C

Performance criteria B description: During the test, degradation of performance is allowed. However, no change of operating state or stored data is allowed to persist after the test. After the test, the EUT shall continue to operate as intended without operator intervention. No degradation of performance or loss of function is allowed, after the application of the phenomena below a performance level specified by the manufacturer, when the EUT is used as intended.

Performance criteria C description: During and after testing, a temporary loss of function is allowed, provided the function is self recoverable, or can be restored by the operation of the controls or cycling of the power to the EUT by the user in accordance with the manufacturer's instructions. Functions, and/or information stored in non-volatile memory, or protected by a battery backup, shall not be lost.

11.6. Test Procedure

The EUT and test generator were setup as shown. The interruptions are introduced at selected phase angles with specified duration. Record any degradation of performance.

11.7. Test result

Ambient Condition : <u>23.4 °C</u> <u>50.5 %RH</u> <u>101.4 kPa</u>						
Test Power supply: <u>AC 230V/50Hz</u>			Test Site: DDT 4# Shield Room			
Memo:						
Operation Mode	Voltage Dips & Interruptions %Ur	Duration (in period)	Phase Angle	Required	Observation	Result (Pass/Fail)
Mode 1	0	0.5P	0°, 180°	B	A	Pass
	0	1P	0°, 180°	B	A	Pass
	70	25P	0°, 180°	B	A	Pass
	0	250P	0°, 180°	C	B	Pass
Observation Description: A: Operation as intend, no loss of function during test and after test. B: EUT will stop working and can recover by itself after test.						

11.8. Test photo



12. Photos of the EUT







Sender:

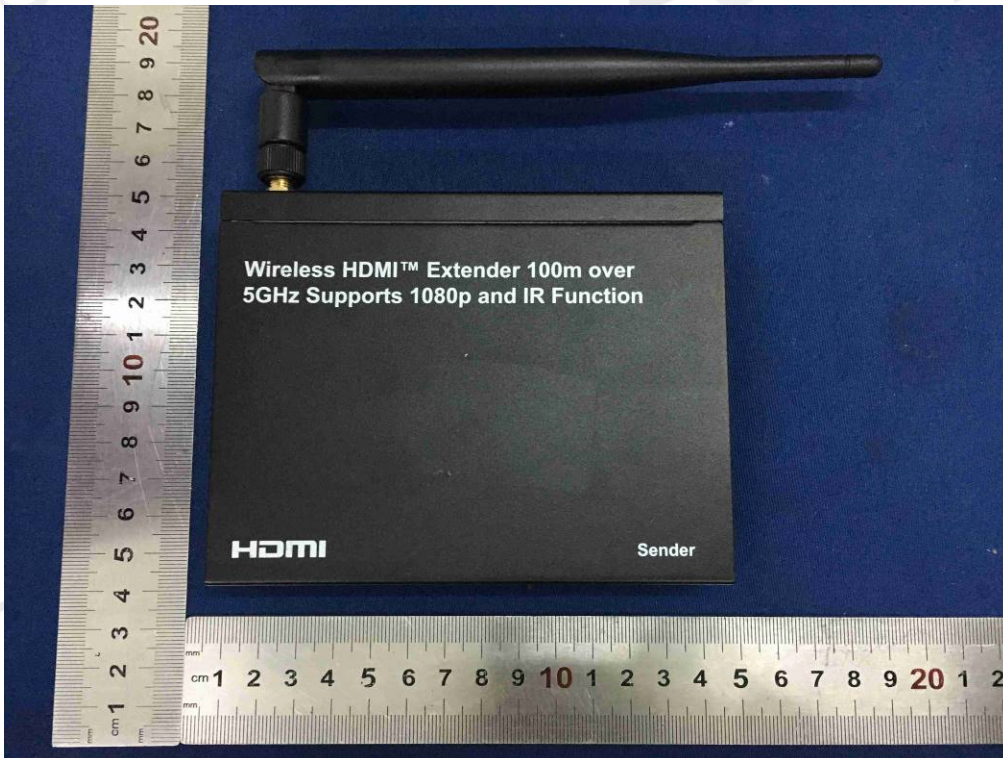







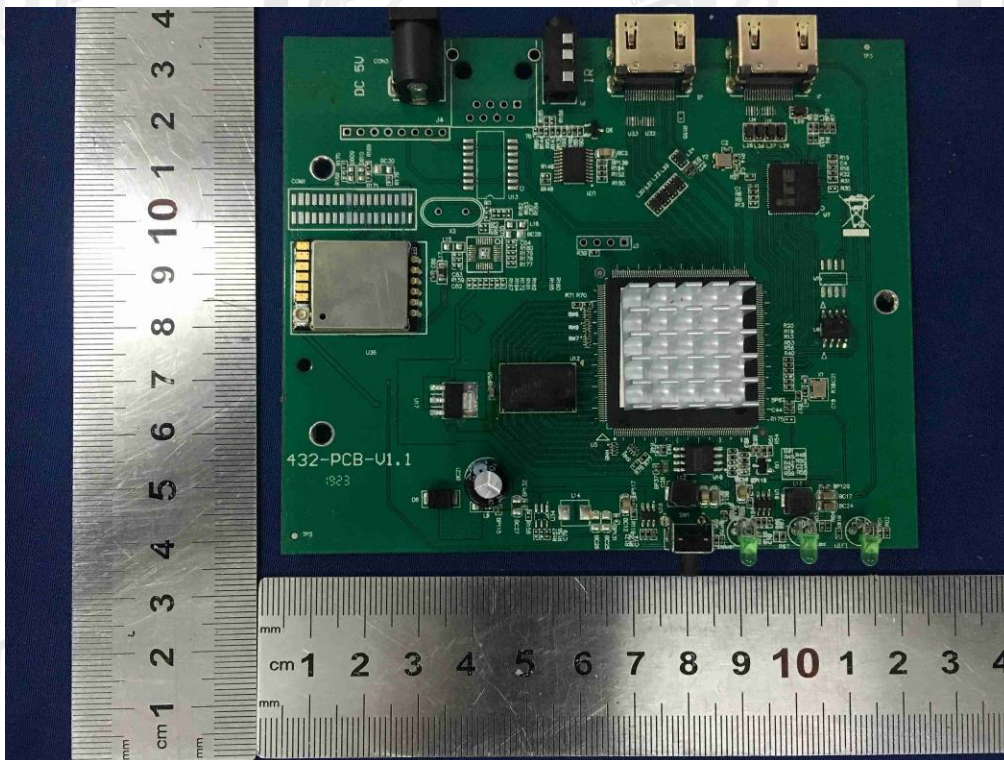
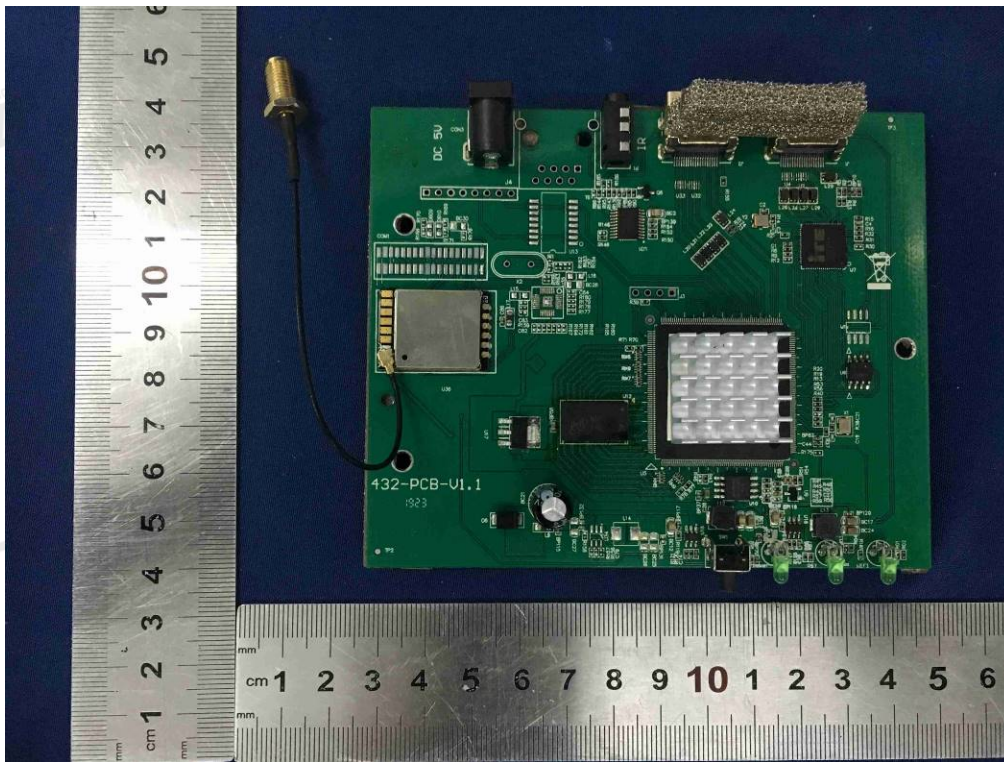

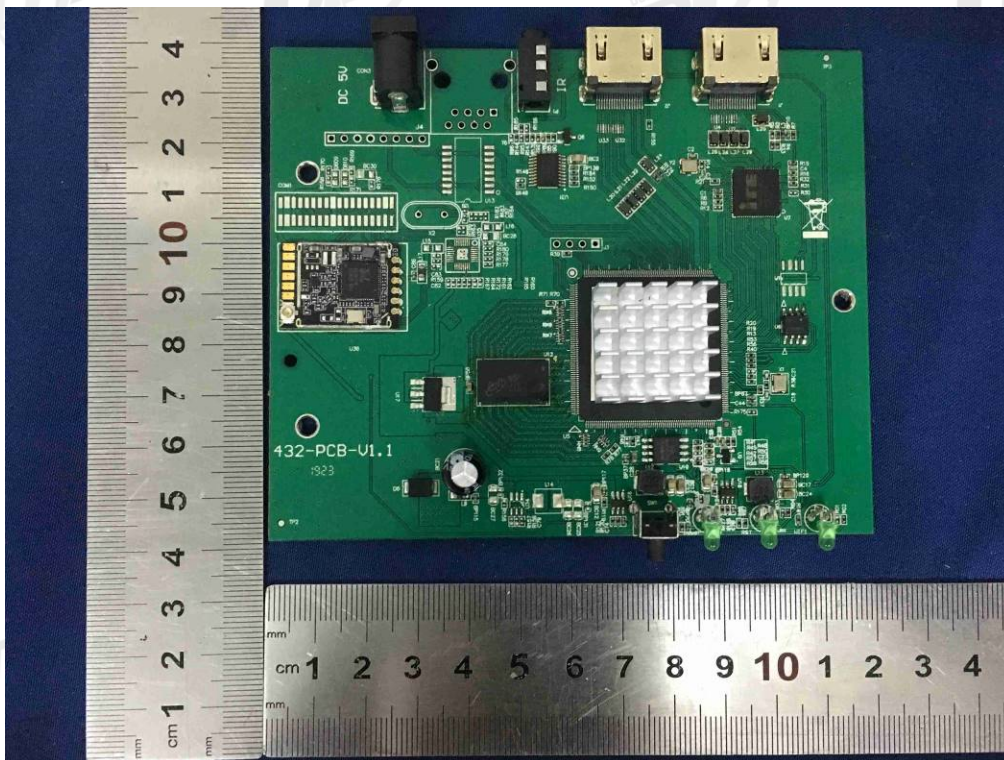
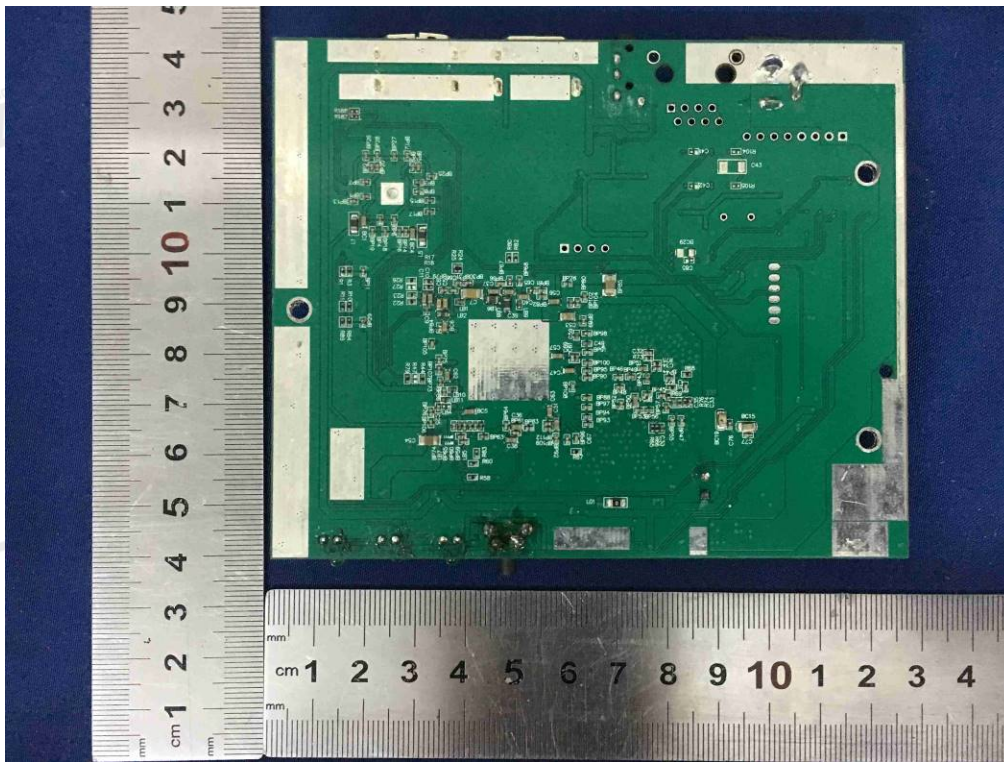

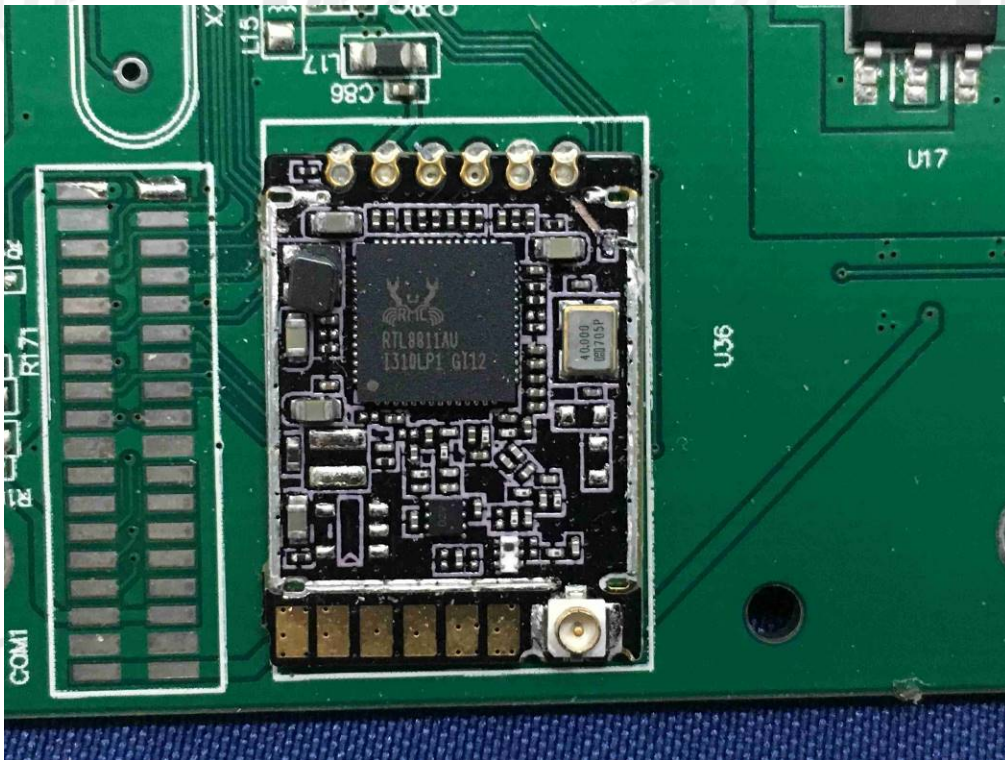
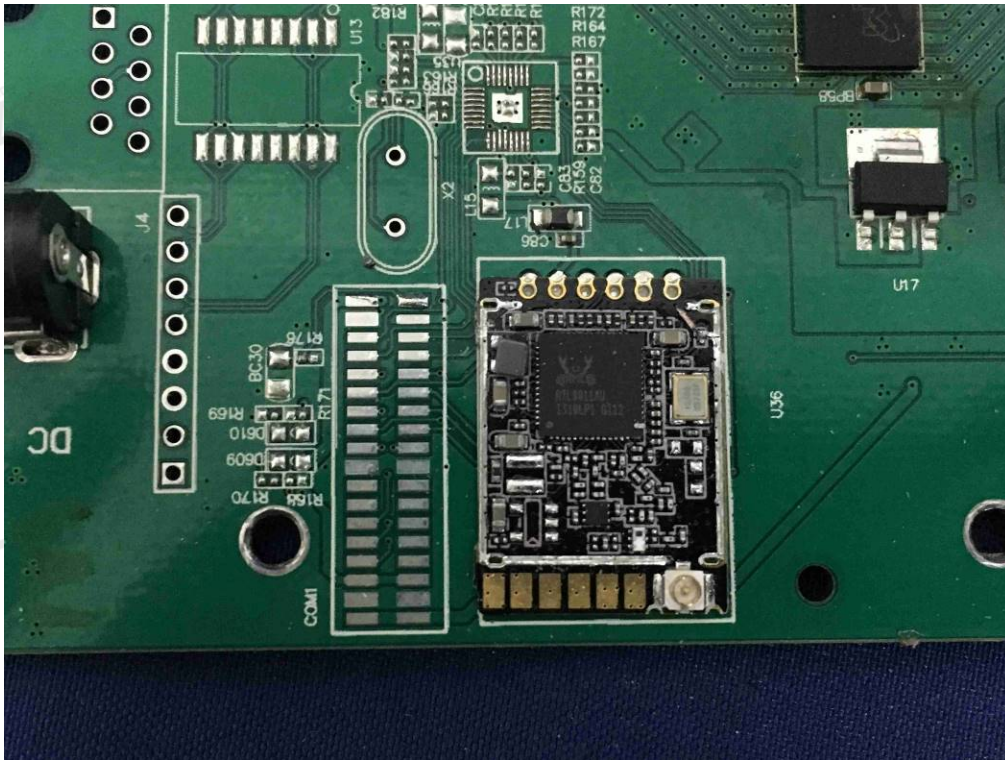



Receiver:

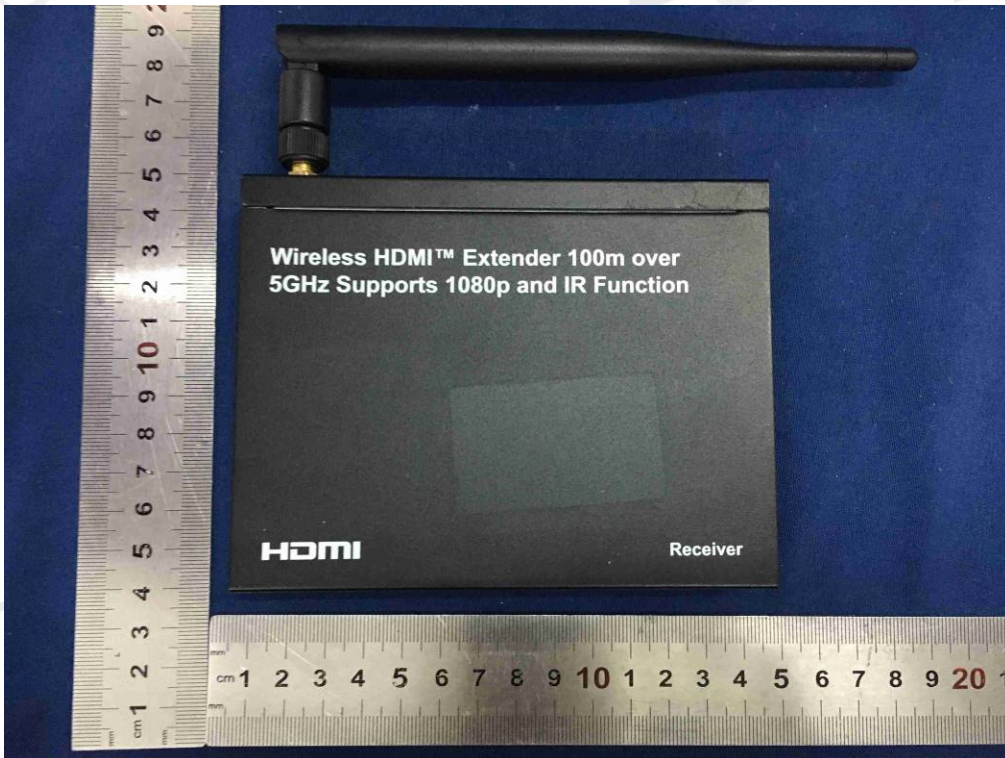



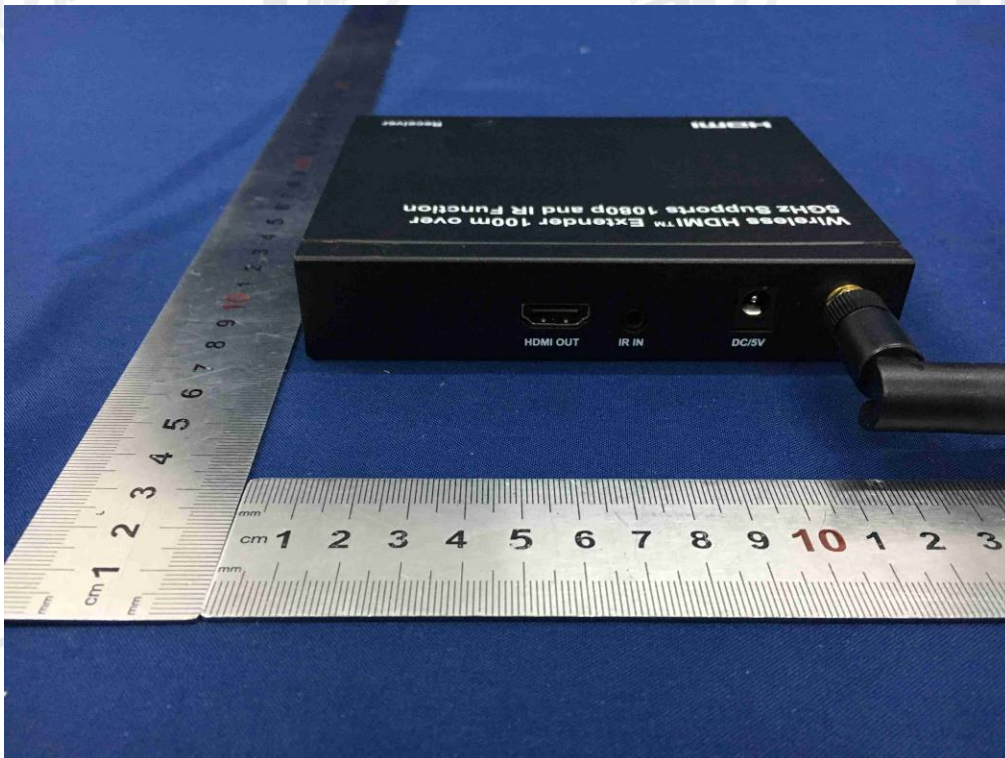



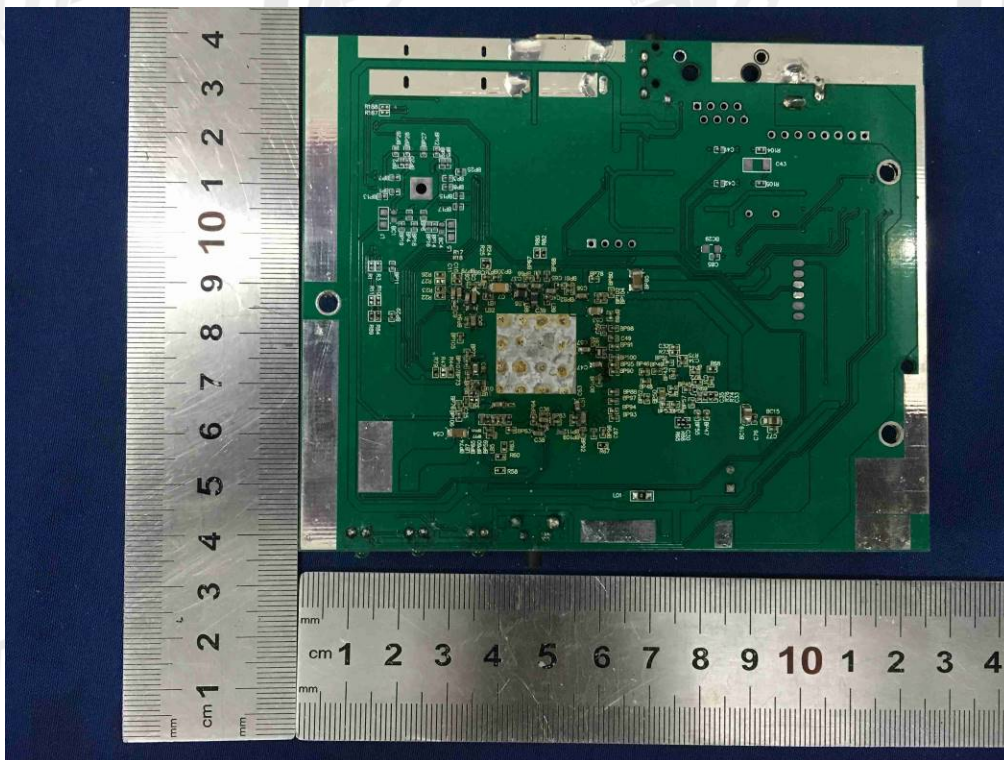
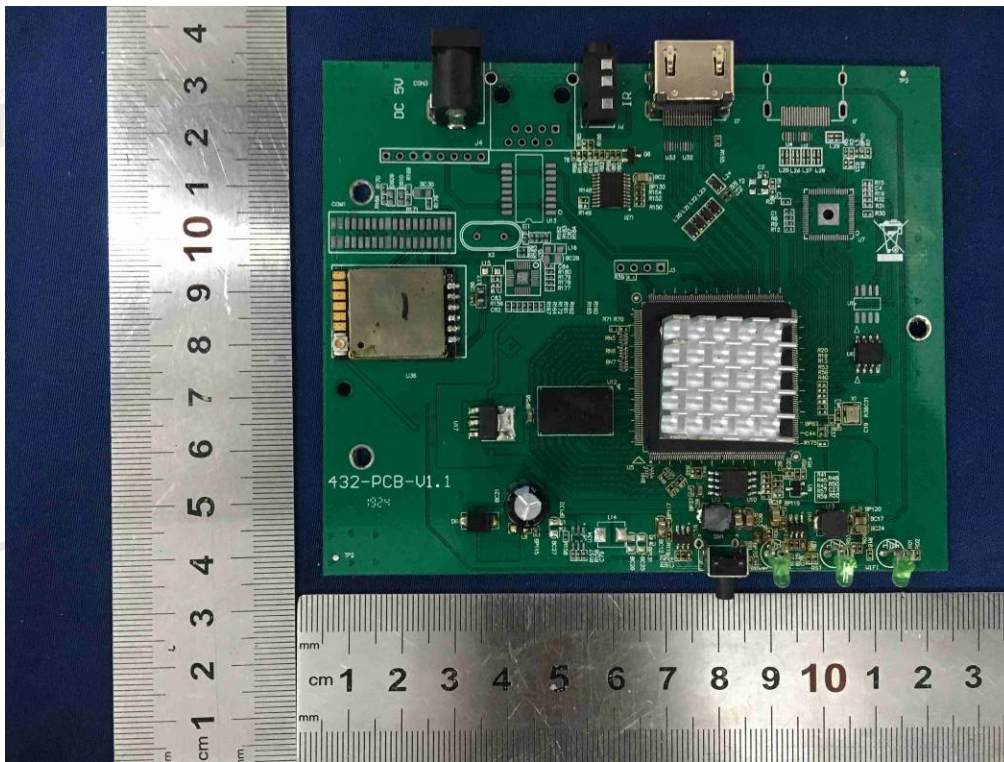

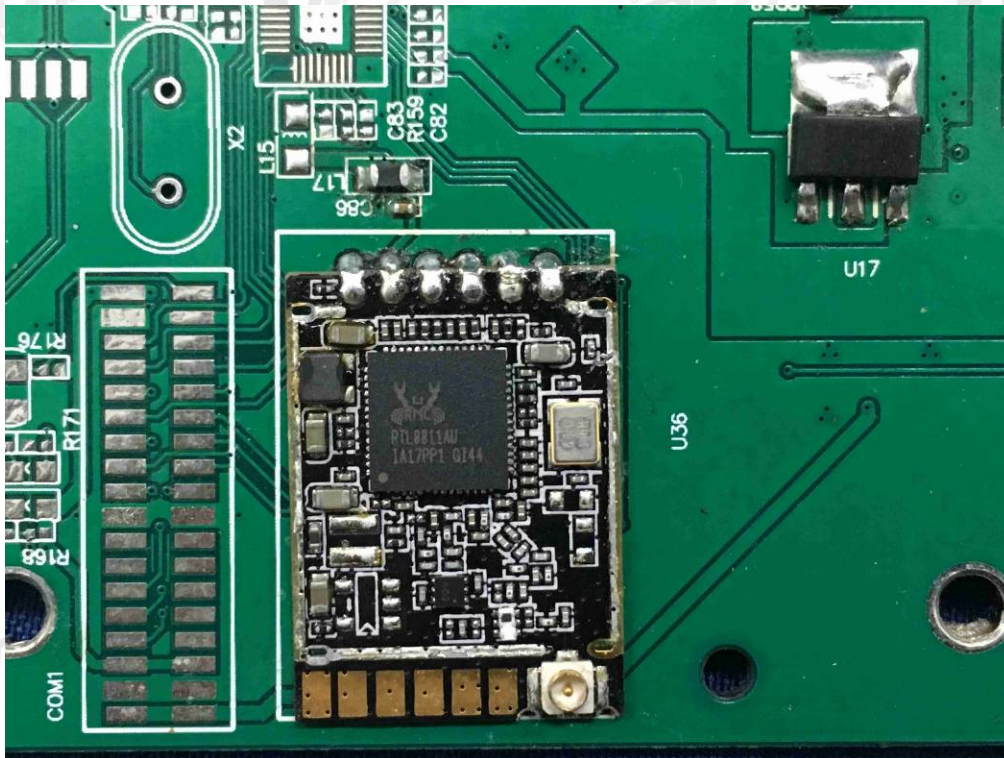
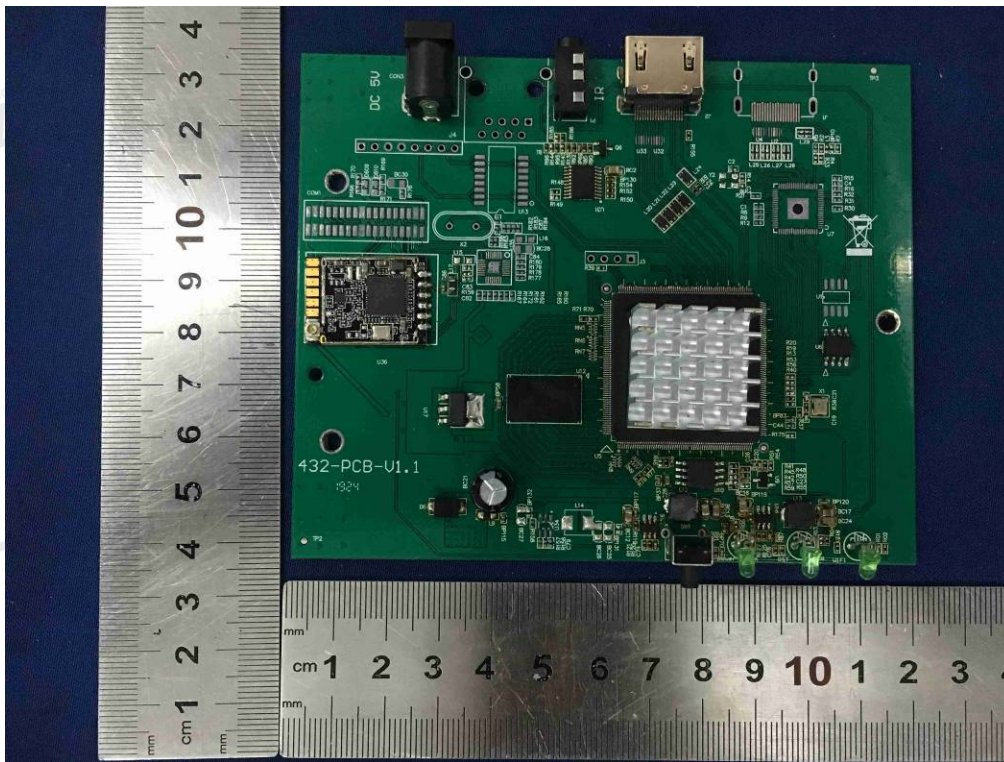

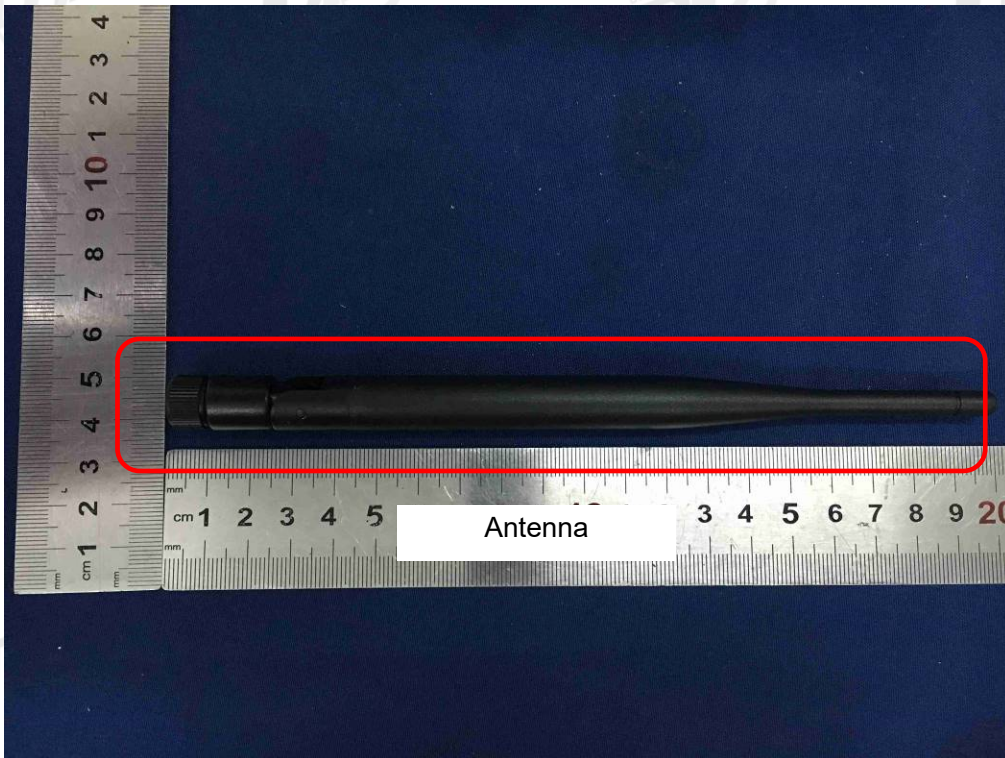
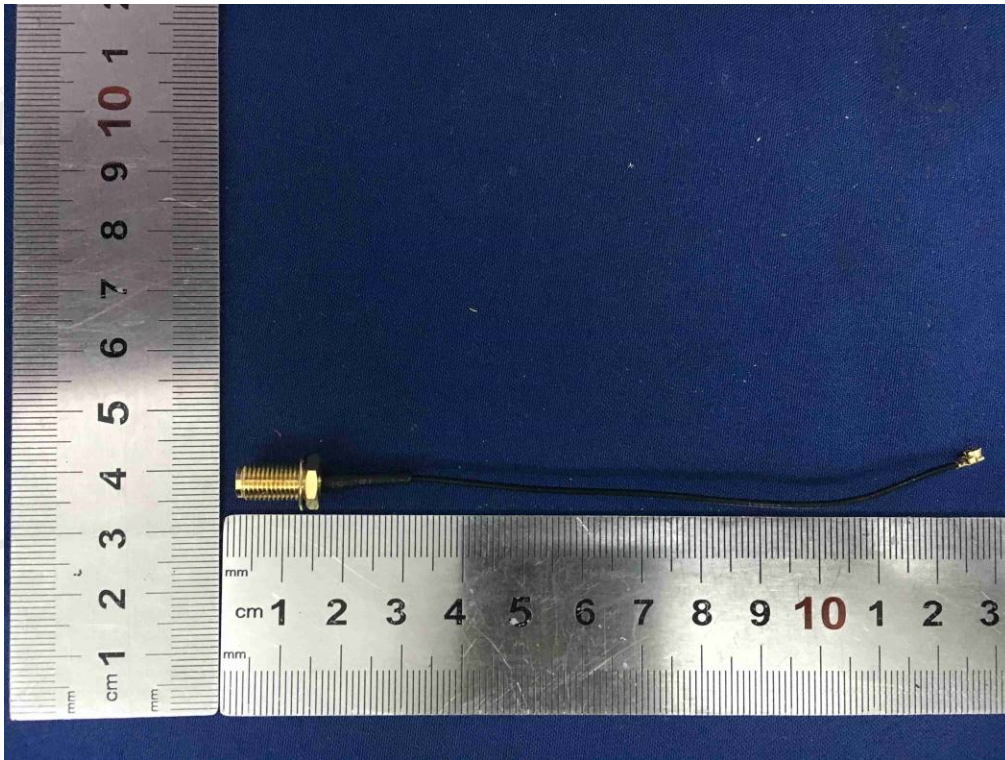

END OF REPORT